



**BEETLE POS Tower 100 Scan&Bag**  
Self-Checkout System

**We would like to know  
your opinion on this publication.**

Please send us a copy of this page  
if you have any constructive criticism on:

- the contents
- the layout
- the product.

We would like to thank you in advance  
for your comments.

With kind regards,

Wincor Nixdorf International GmbH  
RD PD1  
Wernerwerkdamm 16  
Gebäudegruppe 36  
D-13629 Berlin  
Fax: +49 30 5017 1075

---

Your opinion

**Copyright © Wincor Nixdorf International GmbH, 2007**

The reproduction, transmission or use of this document or its contents is not permitted  
without express authority.

Offenders will be liable for damages.  
All rights, including rights created by patent grant or registration of a utility model or design, are reserved.

Delivery subject to availability; technical modifications possible.

# Contents

Introduction.....	1
Components .....	2
Components Inside .....	3
Rotating the top module of POS Tower 100 by 180°.....	6
Maintenance .....	7
ESD (Electrostatic Sensitive Devices) .....	8
Installation and startup.....	9
Before turning on the system.....	9
Setting up the device.....	9
Connecting the cables.....	10
Printer TP07 Compact .....	12
Pulling out the printer .....	12
Changing the paper roll .....	13
Setting the paper roll core diameter.....	13
Choosing a paper roll holder.....	14
Inserting the paper roll.....	15
Removing the paper roll .....	15
Cash Media Dispenser - Vertical Cash-Out .....	16
Modules and function elements.....	18
Function elements.....	19
Cash-out cassette .....	20
Reject / retract cassette .....	21
Removing the cassette.....	22
Transporting the cassette.....	22
Opening the cassette .....	22
Emptying the reject / retract cassette.....	23
Filling the cash-out cassette .....	24
Preparing the banknote bundles.....	24
Inserting banknote bundles .....	25
Possible deformation of banknotes.....	27
Inserting the cassette.....	29
Closing the cassette.....	29
Inserting the cassette.....	30
Cassette initialization .....	30
Status messages (CMD controller).....	31
Checking the note paths .....	33
Coin Dispenser .....	38
Components.....	38
Switching off / pulling out the Coin Dispenser .....	39
Slide in / Rotating the Coin Dispenser .....	40
Factory Settings .....	40
Coin Capacity.....	41

Low Coin Modes .....	41
Alarm Sound .....	41
Low Coin Disabled .....	41
Low Coin Enabled, Even Depletion Off (Dispense by bin or dispense by amount).....	42
Low Coin Enabled, Even Depletion On (Dispense by amount) .....	42
Dispense History .....	42
In System Programming.....	42
External Power supply.....	42
Power Cable .....	42
Communications Cable .....	43
Filling the Coin Dispenser.....	43
Emptying the Coin Dispenser .....	43
Clearing a Coin Jam.....	45
Maintenance.....	45
Trouble Shooting .....	46
Specifications.....	48
Coin Input.....	49
Correcting a coin jam .....	49
CMD V4-Shutter .....	51
Introduction .....	51
Function.....	52
Cash removal .....	52
Error code 28.....	52
Single Banknote Validator.....	53
Function elements and controls.....	54
Validator unit.....	54
Cash boxes.....	56
Removing / inserting the cash box.....	57
Opening / closing the cash box.....	58
Emptying the cash box .....	59
Description of the banknote path .....	59
LEDs.....	60
Optical signals.....	60
General.....	60
Cleaning and maintenance.....	61
Cleaning card .....	61
Validator unit.....	61
Lower section of the single banknote validator .....	63
Transport rollers and transport belts.....	64
Autocalibration .....	66

BEETLE /M-II.....	67
Front view.....	68
Inside view.....	68
Back view.....	69
Central USB Special Electronics Module.....	70
Functions of the special electronics.....	71
Control Panel.....	72
Power Supply Unit.....	73
Views.....	74
Front view.....	74
Rear view.....	75
Description.....	75
Safety functions.....	75
Proximity Sensor.....	77
Introduction.....	77
Function.....	77
Waiter Lock.....	78
Scanner (Scale optional).....	79
Scanner Maintenance.....	79
Scanner Usage.....	79
Scanning Items.....	79
Proper Scanning Technique.....	79
Security Scale.....	80
Adjusting the Security Scale Module.....	80
Coupon Box.....	81
Emptying the Coupon Box.....	81
UPS (Unbreakable Power Supply - optional).....	82
Appendix.....	83
Changing the Safe Code (LG 39E).....	83
Generally.....	84
Programming Manager.....	88
Programming on PC.....	92
Manual programming.....	94
Block Diagram.....	96
Environmental Requirements.....	97
Cleaning Instructions.....	98
Maintenance and Service.....	98
Maintenance for rotating top module.....	98
Approved Cleaning Materials.....	99
Important Notes.....	100
Note on Laser.....	102
Certifications of the manufacturer.....	103
Note on Radio Interference Suppression.....	103
FCC-Class A Declaration.....	103
Recycling the BEETLE /iSCAN Scan&Bag.....	104

## Introduction

The BEETLE POS Tower 100 Scan&Bag is a terminal where the user handles the purchase by scanning, bagging and paying the items on his own. In case of problems an attendant is available for quick support.

The BEETLE POS Tower 100 Scan&Bag is connected to an attendant station. This is a POS system controlling all connected POS Tower 100 Scan&Bag terminals.

BEETLE POS TOWER 100 Scan&Bag offers the following main functions:

- Record function - records items, the customer wants to buy
- Control function - secures the recording of all items
- Payment function - payment may be effected by banking cards, customer cards and accounts, coupons, bank notes or coins. Cash return uses bank notes and coins.

## Components



1	Screen	5	Waiters Lock	9	Coin In	13	Hardtag Detector
2	Receipt	6	Coupon In	10	Note In	14	Bag Holders
3	Scanner / Scale	7	Coin Out	11	Pole Light	15	Pin Pad*
4	Note Output	8	Swipe Card Reader	12	Security Scale	16	UPS

\*The Pin Pad is customer specific, different models and positions are possible

## Components Inside

At the side of the POS Tower 100 Scan&Bag you find the lock for the front door. Put the key into the lock, turn it to the right and swing the door upwards.

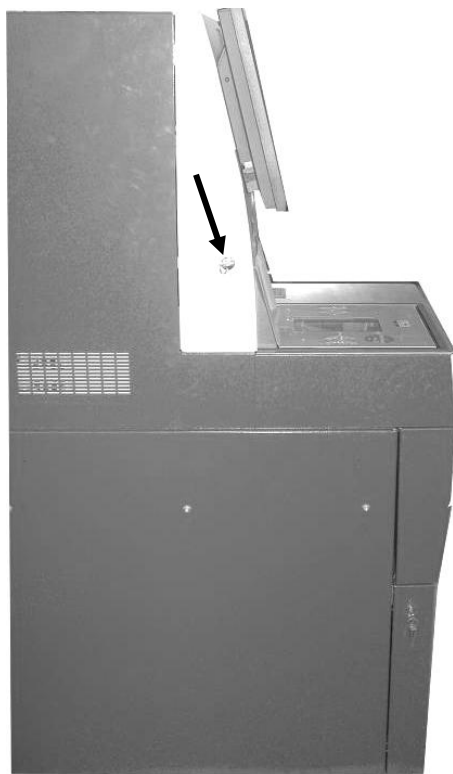

Have a look on the components on the next page.

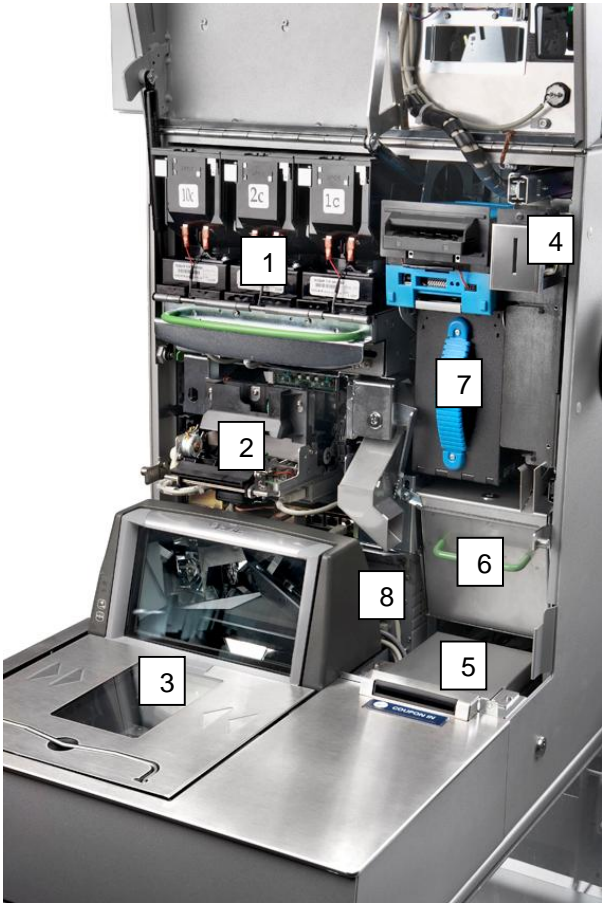

1	Coin Dispenser	5	Coupon Box
2	Printer	6	Coin Box
3	Scanner Scale	7	Note Box
4	Coin Recognition	8	BEETLE /M-II

Behind the bottom door you find the Media Cash Dispenser (1), the CMD Shutter (2) and the central power supply unit in the back of the safe (3). You also find optional Hardtag Detector in the safe.

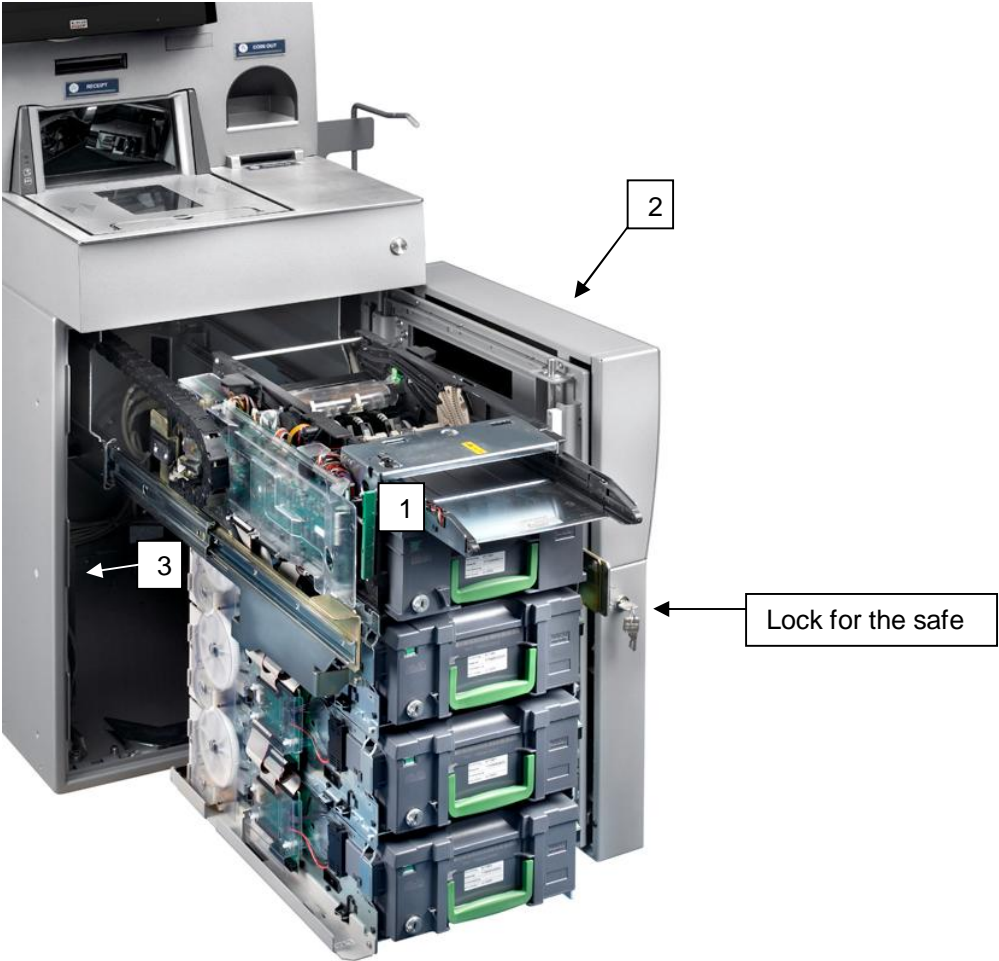

## Rotating the top module of POS Tower 100 by 180°

You can rotate the top module of the POS Tower 100 Scan&Bag including scanner, printer, coin dispenser etc. by 180°.

Therefore, insert the key into the lock (see arrow) and unlock it.



Turn the bag holders (1) down.



Now rotate the top module by 180° using both hands!



## Maintenance

Clean the rotating surface for the top module after 500 rotations or at least once a year. Clean it with commercially available cleaner.



Dry rotating surface after cleaning!

## ESD (Electrostatic Sensitive Devices)



Assemblies containing electrostatic sensitive devices (ESD) *may* be labeled with this sticker.

When installing an assembly or drive, please follow the guidelines below, which apply to all electrostatic sensitive devices (ESD):

- Make sure you are not carrying a static charge before working with components marked as ESD by first touching a grounded object (such as a radiator from a hot water heating system).
- All tools and devices you use must be free from static charges.
- Always unplug the power cord before installing or removing any assemblies.
- Always handle assemblies by their edges.
- Never touch the terminal pins of the circuits on an assembly.

## Installation and startup

**i** Be certain to follow the safety guidelines on page 100.

### Before turning on the system

Unpack the parts and make sure that every item at the packing list is included.

If you find

- shipping damage **or**
- discrepancies between the contents of the package and the packing list **or**
- defects,

please inform your vendor or Wincor Nixdorf International GmbH (WN) sales location immediately. Also provide the packing list and the packing list item and serial numbers for the effected unit. You will find the serial number on the adhesive label on the underside of the system as shown below.

The serial number is located on the label below the bar code.

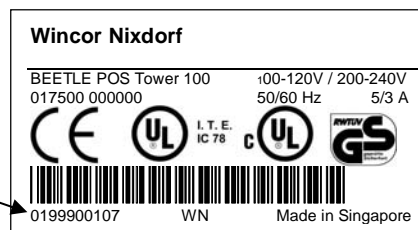

### Setting up the device

Place the BEETLE POS Tower 100 Scan&Bag in a location where the system will not be subject to extreme environmental conditions. The system should be placed on a level surface. Keep the device away from vibrations, dust, humidity, heat and strong magnetic fields.

**i** For further information please read the “Important Notes, Site Preparation and Commissioning” manual.

## Connecting the cables

The cables of the system should be connected in the order described below:

- Make sure that the cash register system is turned off and the power cord of the system has been disconnected.
- Plug in the data cable and secure it.

**i** Never plug data or electrical supply cables (except for USB) when the system is running.



Connectors with thumb wheels can be secured by hand.

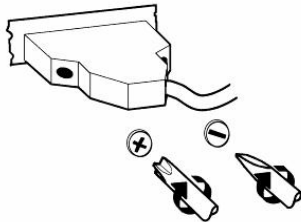

Connectors with metal screws can be secured using a screwdriver. Plastic screws should only be tightened by hand.

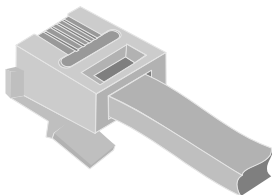

RJ12 connectors lock in place when plugged in.  
LAN connectors lock in place when plugged in.



USB plugs that are not supplied with power do not latch in place when plugged in, and can be unplugged with a gentle pull.

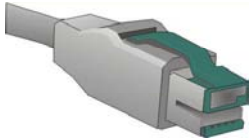

USB plugs that are supplied with power lock in place when plugged in.



TFT plugs lock in place when plugged in.

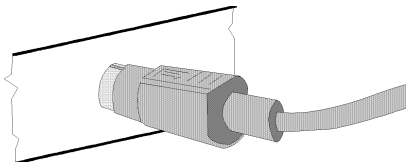

Mini-DIN plugs lock in place when plugged in. Check that the cable is correctly connected by pulling it gently.

You may have to push the plug gently into the socket before it latches.

## Printer TP07 Compact

### Pulling out the printer

Open the front door as shown on page 3. Pull out the printer by using the handle underneath the paper outlet (see arrow).



### Changing the paper roll

#### Setting the paper roll core diameter

When starting the device or when changing the paper roll diameter check whether the selection switch for the paper near end adjustment is set to the correct position.

Core diameter	Paper roll diameter180 mm
18 mm	Pos. A1
25 mm	Pos. A2

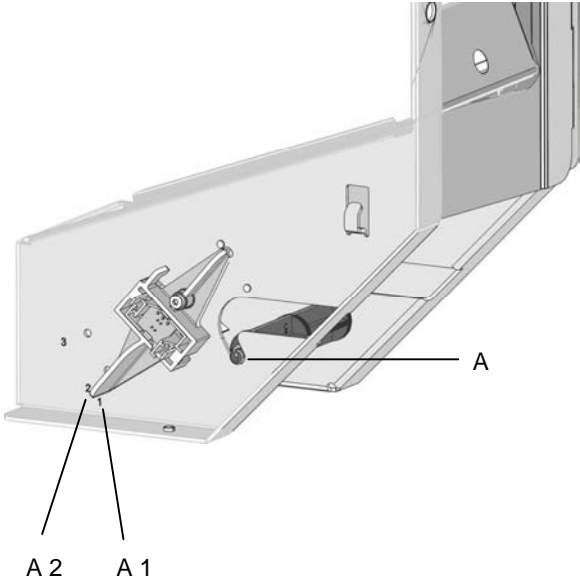

## Choosing a paper roll holder

Choose the roll holder which fits to the paper roll core

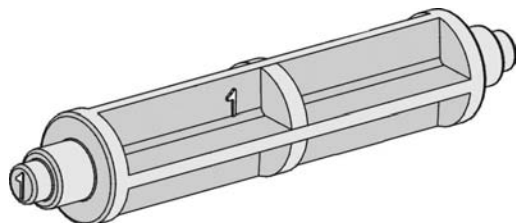

Holder for 18 mm core diameter (identifier 1)

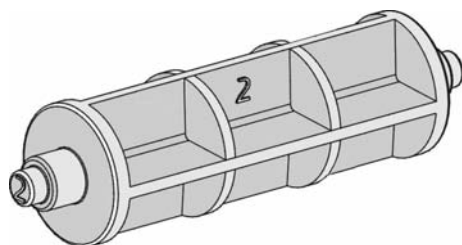

Holder for 25 mm core diameter (identifier 2)

## Inserting the paper roll

Push the paper roll holder into the paper roll core. Insert the paper from behind into the printer as shown in the illustration. Mind the unrolling direction of the paper.

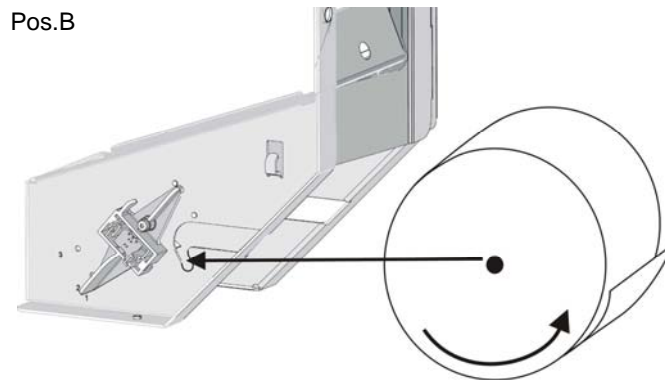

Insert the black mark sensor (top left, top right, bottom left, bottom right) when using paper with black marks.

For correct paper feed or paper transport the front edge of the paper has to be straight and at right angles.

We therefore recommend to cut the paper with scissors.

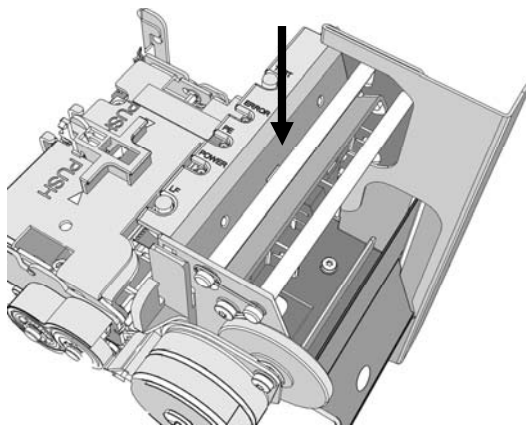

Take the front edge of the paper over the upper axle and feed it into the paper support (see arrow).

Keep pushing the paper into the paper support until it is retracted automatically, the paper is cut off and the printed receipt is output via the presenter.

See also the sticker on the printer.

Remove the receipt that was cut off before.

## Removing the paper roll

Cut off the paper at the paper support. Lift the paper roll out of the printer with the paper roll holder upwards. Use the LINE FEED button to remove the remaining paper.

## Cash Media Dispenser - Vertical Cash-Out

Switch off the device. Insert the key into the lock, turn it to the right and open the bottom door of the POS Tower 100 Scan&Bag.



Now enter the code number of the safe in the data field (1), turn the knob (2) to the right and open the door. The display BA63 is only installed for calibration of the security scale.

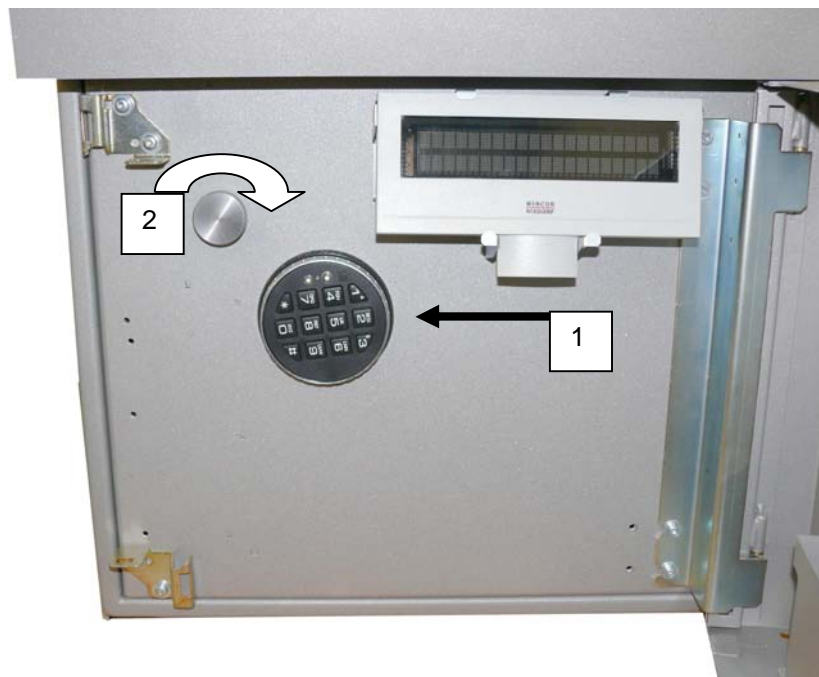

Seize the Media Dispenser (green handle – see arrow) and pull it out completely.



**Modules and function elements**

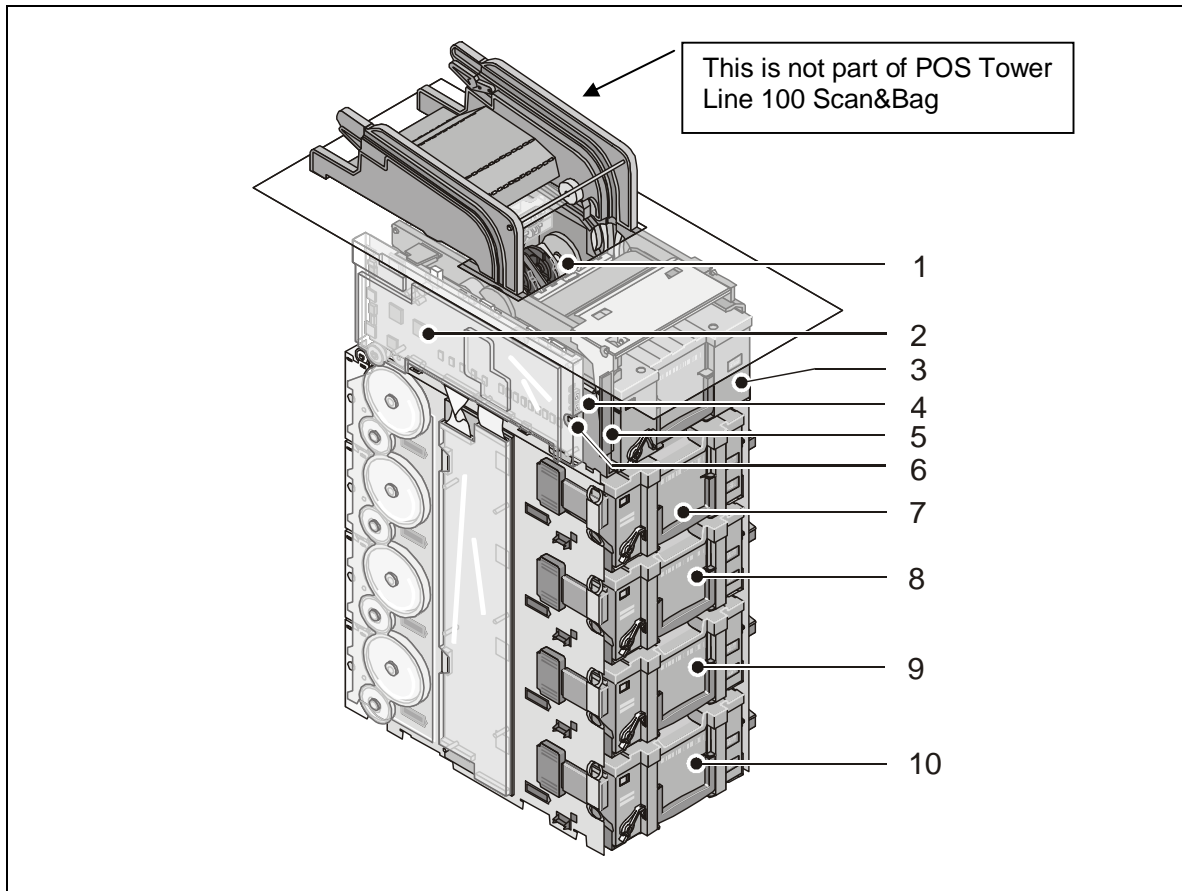

1	Stacker and output transport facility (SAT) Not in POS Tower Line 100 Scan&Bag	6	Function key
2	CMD controller	7	Cash-out cassette 1
3	Reject / retract cassette	8	Cash-out cassette 2
4	Status display	9	Cash-out cassette 3
5	Release lever	10	Cash-out cassette 4 (not available)

**Function elements**

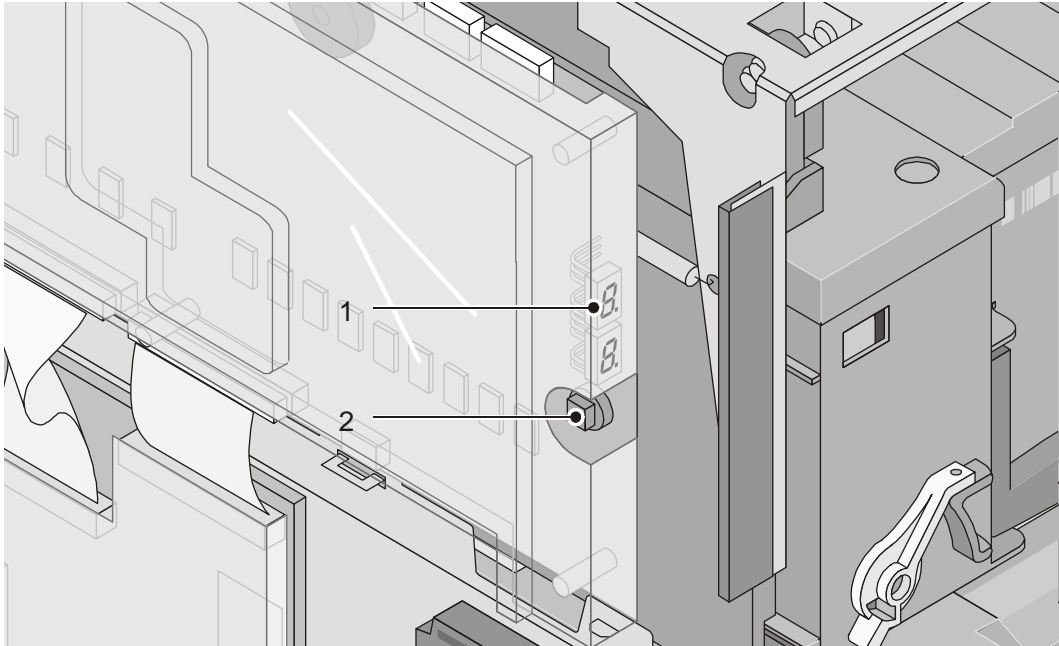

1	Status display (two 7-segment displays, first digit on the top)
2	Function key

**Cash-out cassette**

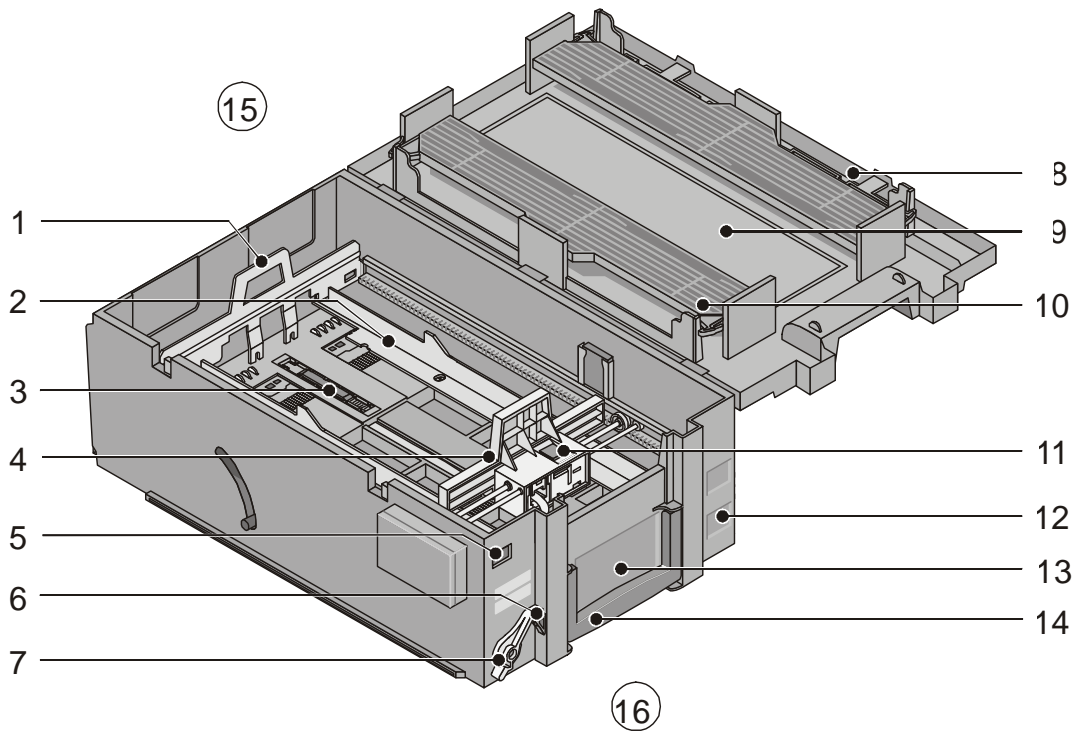

1	Pull-back handle	9	Refill notes
2	Banknote rail	10	Inset for setting the banknote height
3	Slide for low cash sensor (optional)	11	Latching button
4	Pressure carriage	12	Free space for validity identification
5	Tamper indicator blue/green	13	Free space for cassette label
6	Sealing device	14	Cassette handle
7	Locking / unlocking lever (optional lock)	15	Dispensing side
8	Cassette lid	16	Side of cassette handle

**Reject / retract cassette**

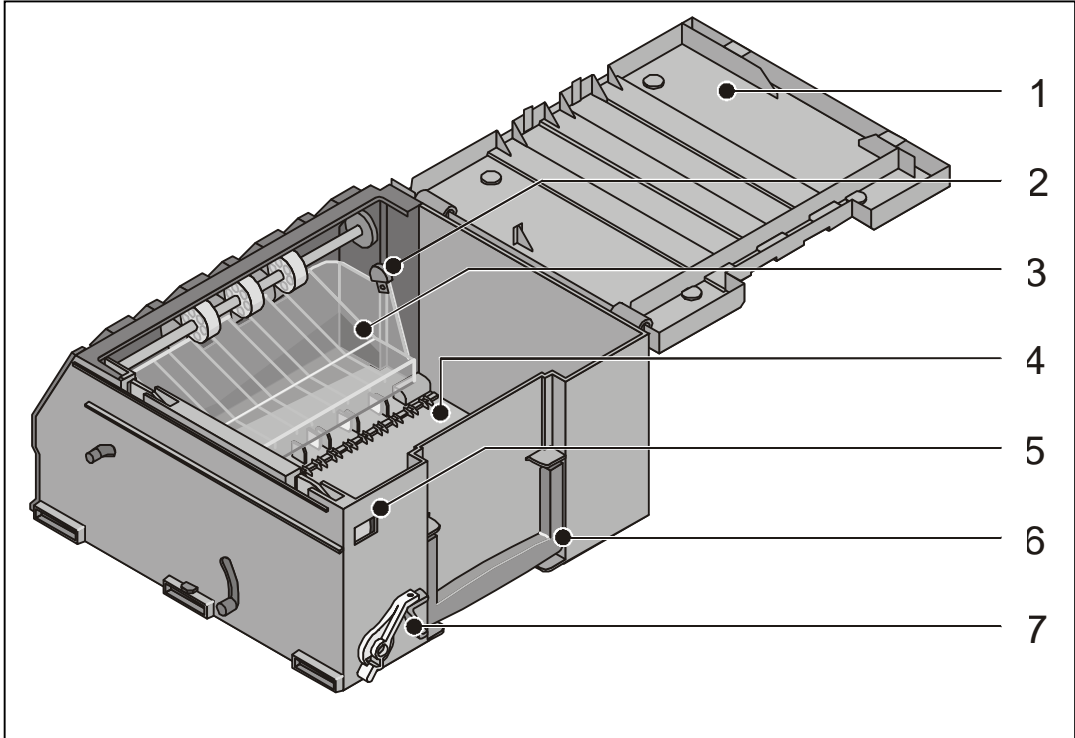

1	Cassette lid	5	Tamper indicator blue/green
2	Retract compartment lever	6	Cassette handle
3	Retract compartment	7	Locking / unlocking lever (optional lock)
4	Reject compartment		

## Removing the cassette

- i** Before cassettes can be removed the BEETLE POS Tower 100 Scan&Bag Terminal should be shut down.

To remove the cassettes from the CMD-V4:

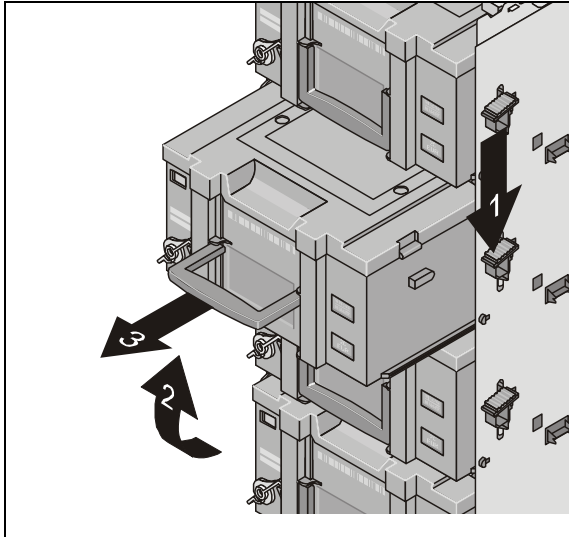

Press the green releasing tab on the right side of the cassette (1).

The released cassette is automatically pushed out of the dispenser by several centimeters.

Raise the cassette handle (2) and pull the cassette out of the CMD-V4 by the handle (2). While pulling the cassette, support it from underneath with your free hand.

## Transporting the cassette

- i** Make sure that the cassette(s) are not damaged or dropped during transport.

## Opening the cassette

- i** The procedure for opening cash-out cassettes and reject/retract cassettes is the same.

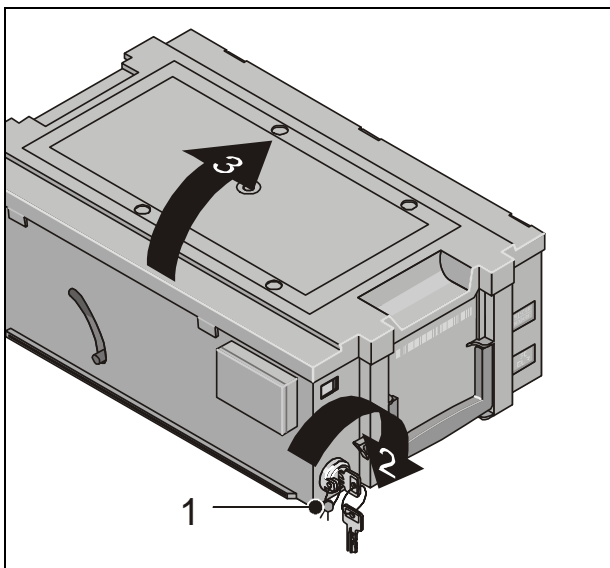

Remove any seal (1) on a cassette with a sealable lock. Insert the cassette key into the cassette lock, turn the key to the right as far as possible (2) and lift the cassette lid in the direction of the arrow (3).

### Emptying the reject / retract cassette

The reject / retract cassette is divided into a reject and a retract compartment.

Banknotes which are not removed by the customer after the cash dispensing procedure are returned to the retract compartment. Cash which has been incorrectly dispensed or which was dispensed for test purposes is stored in the reject compartment.

- Remove and open the cassette (see section "Opening the cassette").

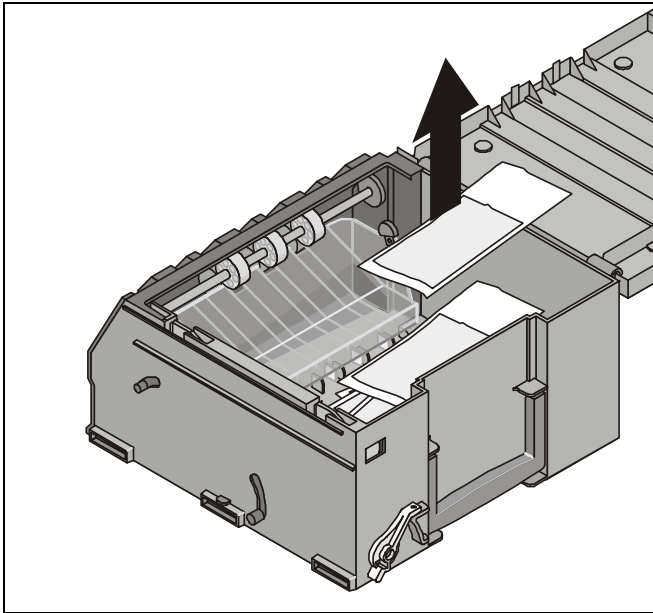

Remove the banknotes from the cassette's reject compartment.

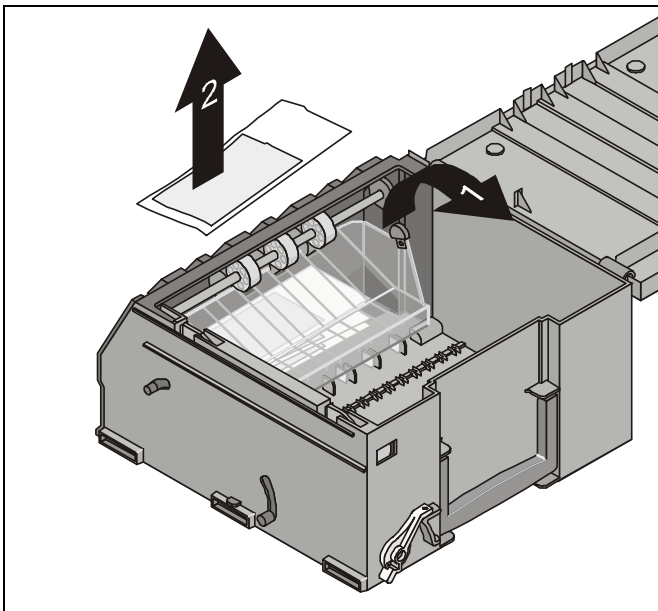

To empty the retract compartment, push the green lever in the direction indicated as far as possible and hold it down. You can remove the cash from the retract compartment with your other hand (2).

### Filling the cash-out cassette

Filling the cash-out cassettes includes the following steps:

- Preparing the cash-out cassette
- Preparing the banknote bundles
- Inserting banknote bundles



In general, all banknotes complying with the requirements of the national banks are suitable for use in the cash-out cassette.

To ensure error-free dispensing, fill the cash-out cassette only with intact and carefully prepared banknote bundles which only contain notes of the same value.

### Preparing the banknote bundles

Check the banknotes for damages before you put them into the cash-out cassettes. Sort out the damaged banknotes and/or remove clips, needles or other foreign objects



The following banknotes should be rejected: torn, glued, folded, creased, stapled or clipped banknotes.

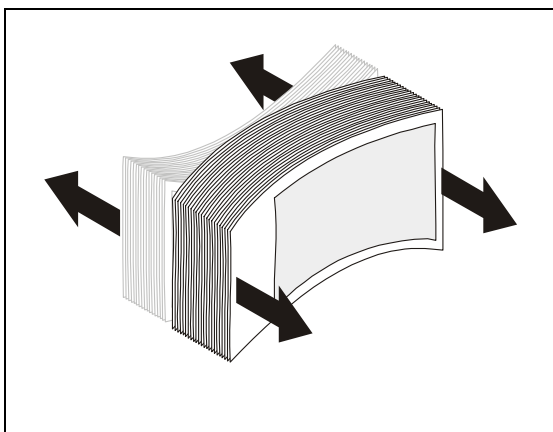
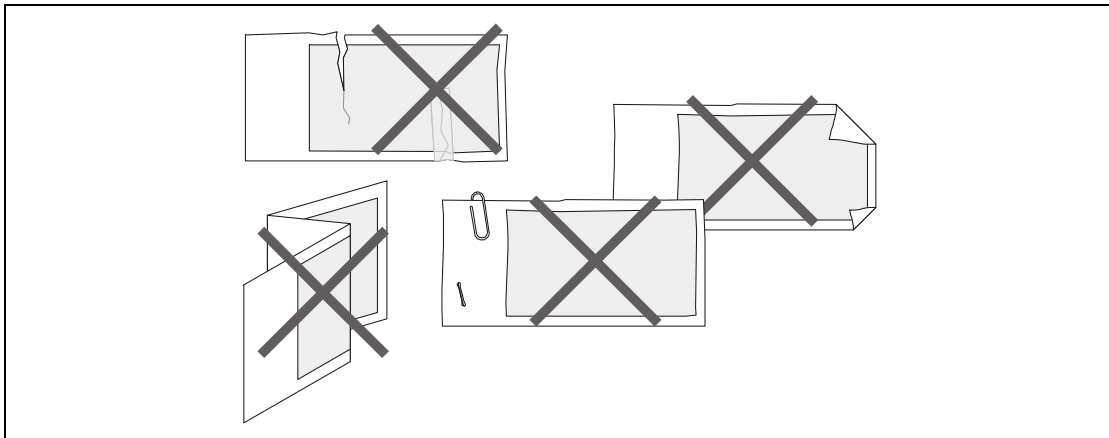

If you use new bank notes / bank note bundles, you must separate the bank notes at the cutting edges. Carefully fan the bank note bundles and bend and twist them repeatedly in various directions.

## Inserting banknote bundles



Also follow the instructions for filling the dispenser cassette on the inside of the cassette cover.

## General instructions for filling the cassette

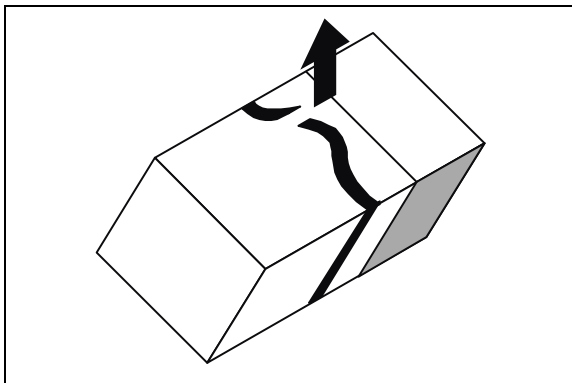

Remove any existing bank wrappers made of paper, plastic or rubber before inserting the banknote bundle.

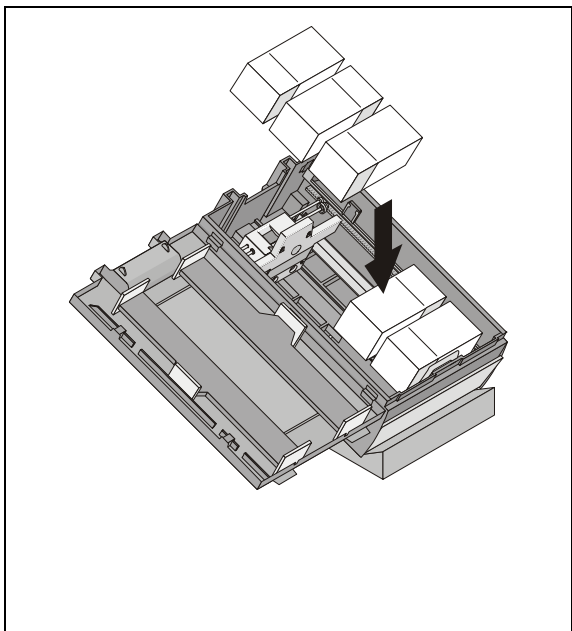

You should always insert the banknote bundles into the cash-out cassette so that the silver stripes or other raised embossing of the individual bundles are alternately pointing to the left and to the right.

**New and used banknote bundles**

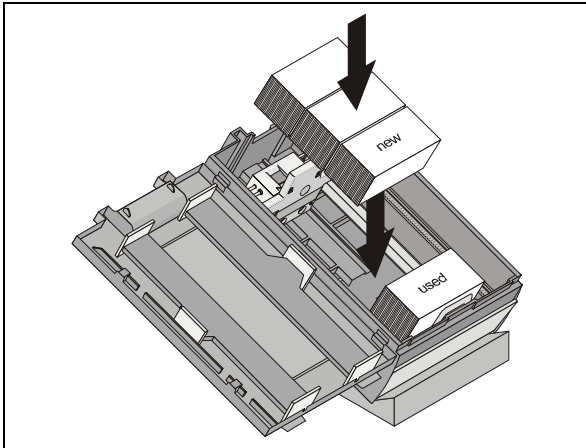

If you use new and used banknote bundles in one cassette, always insert the bundles with the used banknotes into the cassette first.

Then insert the bundles with the new banknotes after you separated them at the cut edges (see the section "Preparing banknote bundles").

**Deformed banknote bundles**

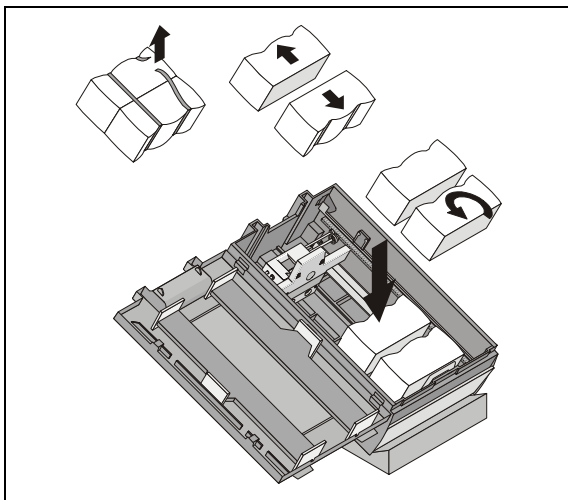

Insert banknote bundles which were deformed by packaging (bands with paper, plastic or elastic bands) as follows:

Split the banknote bundle and turn the first half of the bundle so that the bent side is pointing towards the pressure carriage.

Insert the two bundle halves into the cassette as shown in this picture.

Please do not use any extremely deformed banknotes.

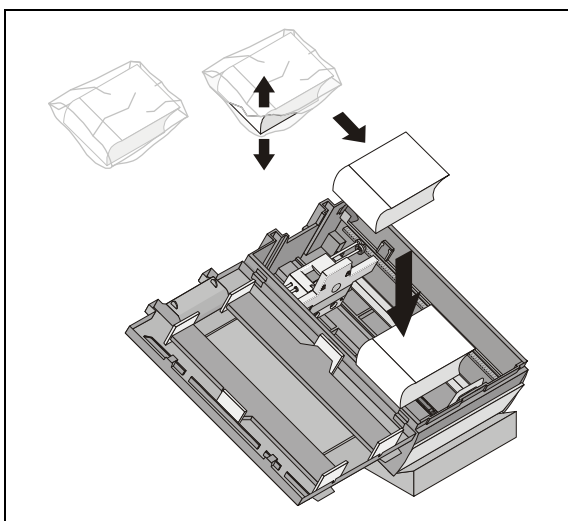

Always insert banknote bundles which are bent horizontally into the cash-out cassette in such a way that the side of the bundle bulging out is pointing towards the pressure carriage.

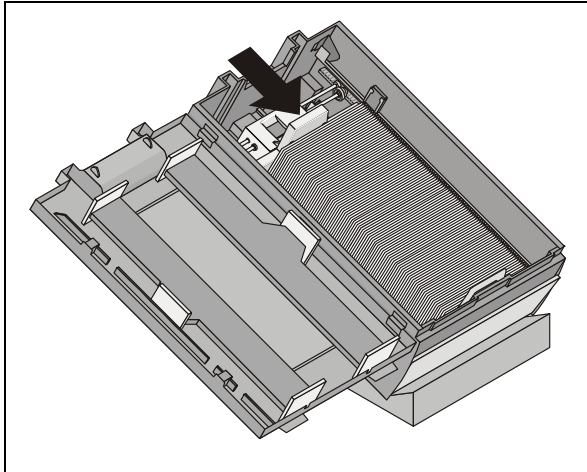

Take the banknote bundles from the packaging, fan the banknotes and put them into the cassette as shown in the picture.



Press the green latching button on the pressure carriage and push the carriage against the banknotes far enough to prevent them from falling over. The inserted banknotes do not need to be pressed together.

Close the cash-out cassette and re-insert it (see section "Inserting the cassette").

**Possible deformation of banknotes**

Type A: Deformation near the hologram	Type B: S shape	Type C: Wavy shape
		

The following illustrations show in which order the deformed banknotes have to be inserted.

Note that the deformed corners of the banknotes must always point to the side from which the notes are dispensed. The bulging side always has to point to the pressure carriage / cassette handle.

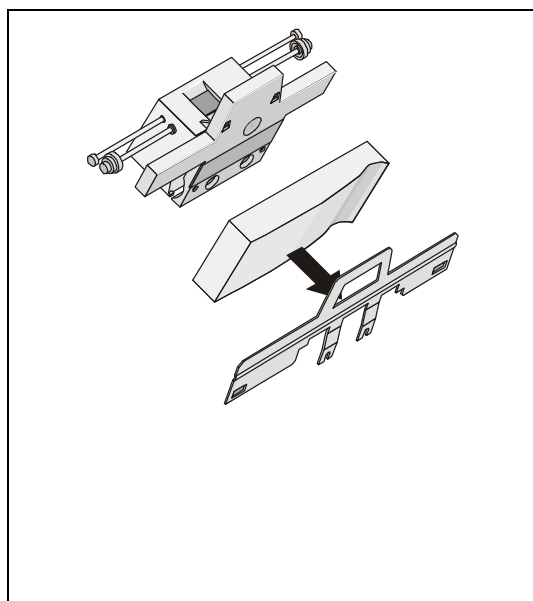

Type A:

Turn the bundle so that the deformed corner of the banknote is pointing not to the pressure carriage.

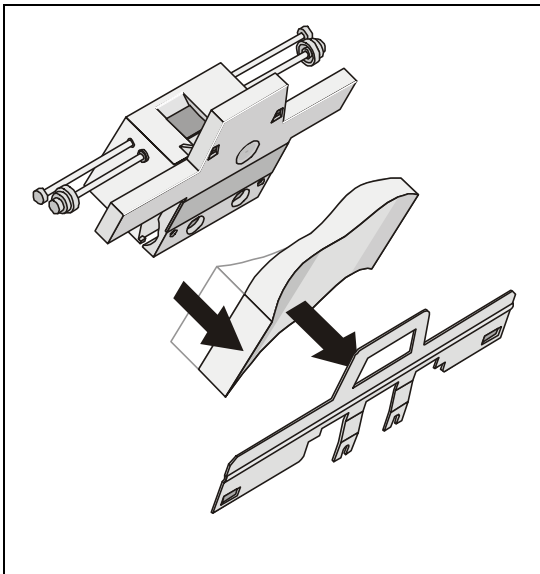
**Type B:**

Bundles whose S shape is pronounced and exceeds 5 mm should not be used.

If no other banknote bundles are available, the entire bundle needs to be formed to a U shape as to be fit for use. Insert these bundles so that the deformed corners are pointing at the bottom to the pressure carriage.

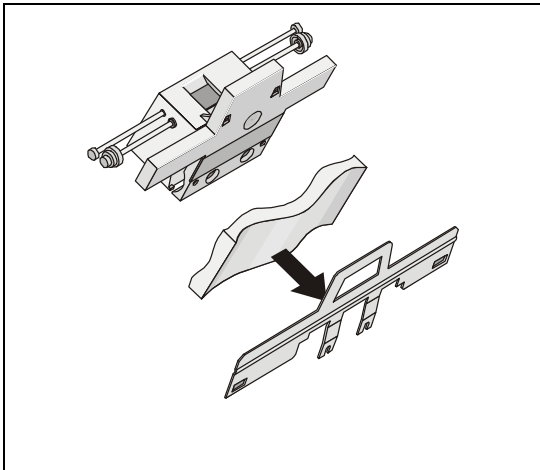
**Type C:**

If the bundle has a wavy shape as a result from having been tied, turn it so that the deformed corners are pointing to the pressure carriage.

### Inserting the cassette



The procedure for inserting cash-out cassettes and reject/retract cassettes is the same.

### Closing the cassette

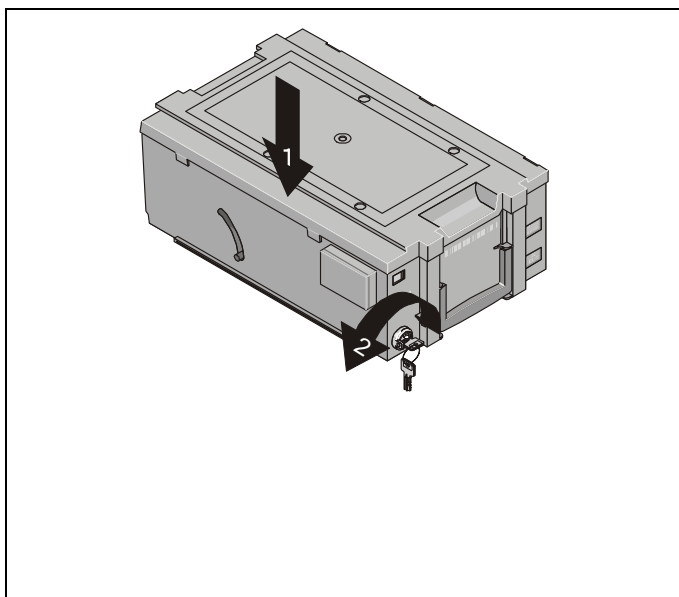

If the cassette has a lock, close the cassette lid (1) and turn the key (2) to the left as far as possible. Pull the key from the cassette lock.

## Inserting the cassette



Normally the tamper indicator (1) is 'green'. If the indicator is blue, the cassette has been tampered with or has been forced open (tamper indicator).

To switch the tamper indicator to green, proceed as follows:

- Unlock the cassette using the key and turn the locking/unlocking lever to the left. Open the lid (see section "Opening the cassette").
- Close the cassette lid and turn the locking / unlocking lever to the left as far as possible. Lock the cassette using the key (see section "Closing the cassette").

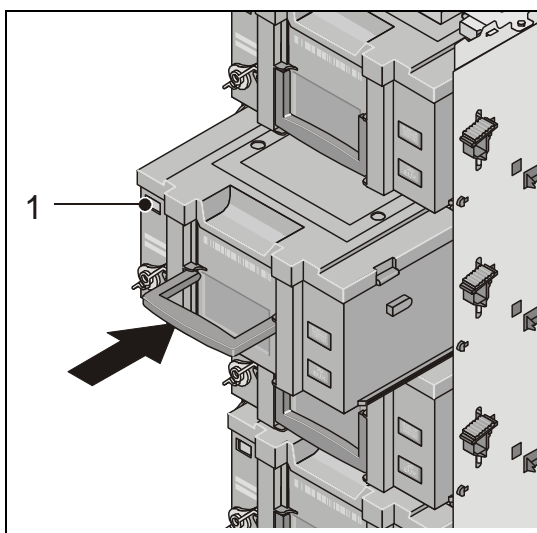

Push the cassette back into the CMD-V4 in one uninterrupted motion until it audibly latches into place. Wait for the single signal tone confirming the correct pressure build-up in the cassette.

- If a triple signal tone sounds instead of a single tone, remove the cassette and check the contents of the cash-out cassette (see the instructions in the section "Filling the cash-out cassette"). Then try again to insert the cassette.

The acoustic warning (triple signal tone) is accompanied by a message on the status display of the controller (ZAC).

Example:

- Cash-out cassette 1

## Cassette initialization

The initialization of the cassettes is necessary in case of new types of banknotes or cassettes. With the initialization the system will be informed about the cassette number, the currency and the denomination of the banknotes. If necessary, you can enter more parameters.

Please observe the product-specific and bank requirements concerning change of standard or individual changing of cassettes. Please obtain this information from the bank's administration.

**Status messages (CMD controller)**

The CMD's controller status messages are listed in the following table. The status messages, their meanings and the remedies you must employ are explained so that you can eliminate CMD-V4 problems.

If, contrary to expectations, you are unable to fix the problem, you should contact the Service. The two-digit codes indicate the following error messages:

No.	Meaning	Remedy
off	No power supply	Switch on the device.
00	Start-up (after RESET or electronics self-test)	Wait until start-up is complete.
00	Controller OK	
00	No error	-
01	Software faulty	Switch the device off and on.
05	Communication problem with Chip Card controller	Perform a reset using the function button. If error message '05' does not disappear, contact customer service.
06	Communication problem with Chip Card / or wrong Chip Card inserted (Chip Card number not '226-0PR').	Perform a reset using the function button. If error message '06' does not disappear, contact customer service.
11	Missing software (download)	Perform a reset using the function button. If error message '11' does not disappear, contact customer service.
22	Safety switch open	Insert the CMD-V4.
33	Device disable present	Remove banknote bundles from the CMD-V4. Reset the device lock using the product-specific software (see chapter "Basic Operation", section "Calling the product-specific software").
44	CMD-V4 minimum configuration is missing	Insert and log in cassette (reject and cash-out cassette required).
22	Belt drive of clamp defective	
18	Banknotes jammed during dispensing	Check the cash paths in the stacker, in the area of the stacker wheels and in the dispenser modules (see section "Checking the cash paths"). Move the CMD-V4 in the safe to the cash-out position and wait for the system to boot. If error message '18' does not disappear, contact customer service.
19	Clamp transport defective / blocked	Check the cash paths in the output transport (see section "Checking the cash paths"). Move the CMD-V4 in the safe to the cash-out position and wait for the system to boot.

20	Single reject switch (MA2/SM1) defective / blocked	Check the cash paths in the output transport (see section "Checking the cash paths"). Move the CMD-V4 in the safe to the cash-out position and wait for the system to boot.
21	Faulty measuring station (DDU)	
22	Photo sensor amplifier faulty or photo sensor initialization unsuccessful.	Clear the cash paths (see section "Checking the cash paths"). Move the CMD-V4 in the safe to the cash-out position and wait for the system to boot. If error message '22' does not disappear, perform a reset using the function button. If you do this three times without success, contact customer service.
23	Routing disk (DCM2/SM3) defective / blocking	If you cannot pull out CMD-V4, perform a reset using the function button. If error message '23' does not disappear, contact customer service. If you can pull out the CMD-V4, check the cash paths in the stacker and output transport (see section "Checking the cash paths"). Move the CMD-V4 in the safe to the cash-out position and wait for the system to boot.
24	Reject/retract drive (MA6) defective / blocked (lifting magnet)	Empty the reject compartment of the reject / retract cassette (see section "Emptying the reject / retract cassette"). Check the cash paths in the stacker (see section "Checking the cash paths"). Move the CMD-V4 in the safe to the cash-out position and wait for the system to boot.
25	Dispensing drive (DCM 1) defective / blocked	Clear the cash paths (see section "Checking the cash paths"). Move the CMD-V4 in the safe to the cash-out position and wait for the system to boot.
26	Stacker wheel drive (SM 9) defect / blocked	Check the cash paths in the stacker and output transport (see section "Checking the cash paths"). Move the CMD-V4 in the safe to the cash-out position and wait for the system to boot.
28	Shutter error	Check the shutter. Perform a reset using the function button.
29	Cash-out photo sensor covered (manipulation)	Check the cash paths in the output transport (see section "Checking the cash paths"). Perform a reset using the function button.
3X	Too many problems during dispensing from cassette x (x = 1 – 6)	Bundle rejects can be caused by extremely deformed banknotes or banknotes that are extracted in an uncontrolled way or by problems with the photo sensors. This error can be ignored the first time it occurs (warning). If the error keeps occurring, please proceed as follows: <ul style="list-style-type: none"> <li>- Remove the cassette from dispenser module 'x' and check contents of banknotes: Is the correct banknote type in the cassette? Are the front banknotes deformed on one side? Is the pressure against the front banknotes even on the right and on the left side?</li> <li>- With the cassette removed check the dispensing area in the dispenser module for stuck banknote scraps (see section "Checking the cash paths").</li> <li>- Check the transport path from cassette 'x' to the clamp for jammed banknotes/scraps (see section "Checking the cash paths").</li> <li>- Check the connectors at the CMD controller.</li> <li>- Determine the reference value (see section "Determining the reference value").</li> </ul>

No.	Meaning	Remedy
4 X	Banknotes cannot be dispensed or incorrect pressure on notes in new cassette (x = 1 - 6)	Check the contents of cash-out cassette 'x' for position and quality of banknotes (see sections "Preparing banknote bundles" and "Inserting the banknote bundles"). Check the dispensing area for stuck banknotes (see section "Checking the cash paths"). Place the cassette in position again and check the function with a test dispense (see section "Function test").
5 X	Too many bad banknotes (x = 1 - 6)	Check the contents of cassette 'x'.
6 X	Cassette defective (x = 1 - 6)	Replace the defective cassette with a new initialized cassette.
7 0	Banknote measuring station (DDU) not ready	Check whether there is a banknote jam in the upper dispensing unit. Are the cables connected? If the error message does not disappear, contact customer service.
7 X	Dispensing sensor PSDx dirty or pressure sensor faulty (x = 1 - 6)	
8 X	Cassette empty sensor PSEx dirty (x = 1 - 6)	
9 0	Photo sensor PS 1 dirty	
9 1	Photo sensor PS 18 dirty	
9 2	Photo sensor PS 2 dirty	
9 3	Photo sensor PS 27 dirty	
9 4	Photo sensor PS 28 dirty	

### Checking the note paths

Before checking the banknote paths, you should perform the following steps:

- Activate the product-specific software
- Open the safe
- Holding the green release lever, pull out the CMD-V4 as far as possible



If the release lever jams, you must check the current position of the clamp. If possible, push the clamp carefully back to its home position. Perform a reset using the function button. Now check whether you can remove the CMD-V4.

### Checking the dispensing areas



In the dispenser modules the vertical transport (at the rear) and the dispensing area (inside the device) must be checked.

The dispensing areas can only be checked when the cassettes have been removed from the dispenser modules (see section "Removing the cassette").

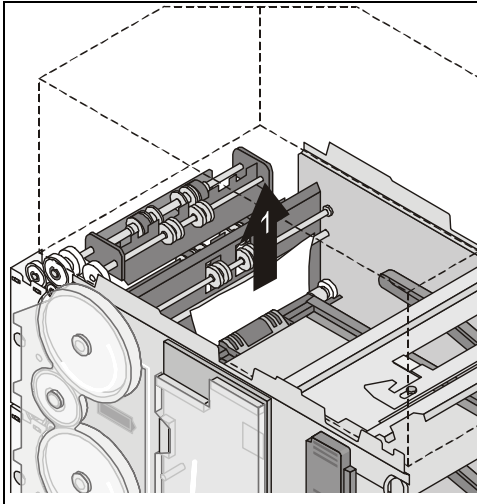

Check the dispensing area of each dispensing module for banknotes and if necessary remove the notes (see arrow).

- Re-insert all cassettes which were removed (see section "Inserting the cassette").
- Log on the cassettes using the product-specific software (see chapter "Basic Operation", section "Calling the product-specific software").

### Checking the stacker and output transport



Do **not** try to open the clamp by force; you could damage it.

#### Stacker wheel area

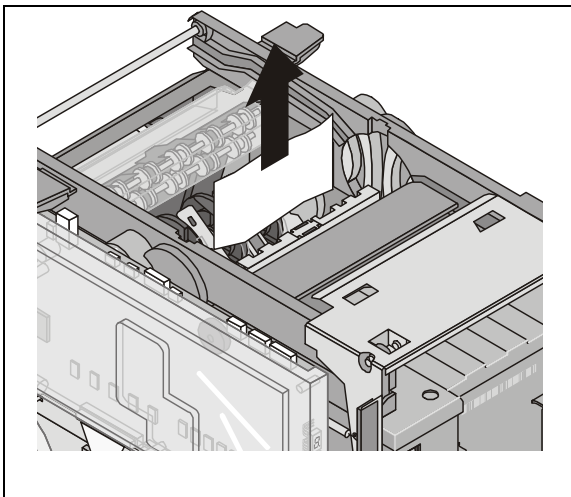

Check the area around the vertical transport and if necessary remove any notes.

### Single reject area



The function of the single reject depends on the individual configuration.

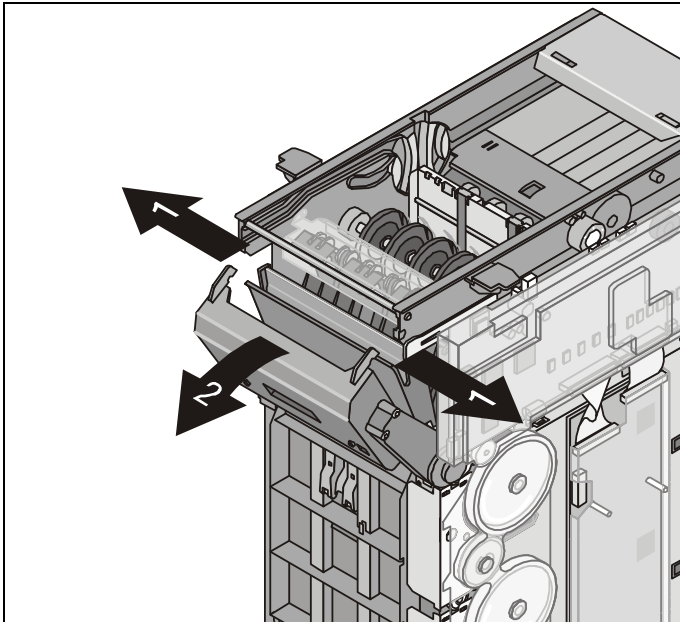

Press the green release levers (1) outwards and pull the flap (2) forwards.

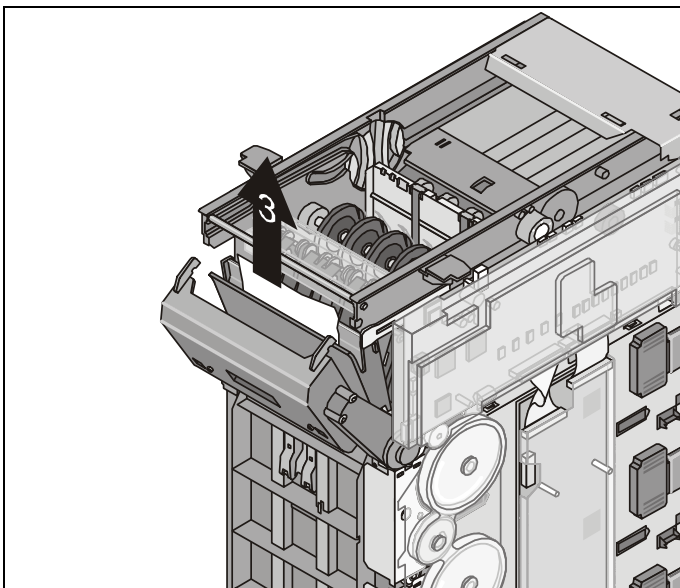

Check the area and if necessary remove the banknotes (3).

### Gear tracks of the stacker and output transport

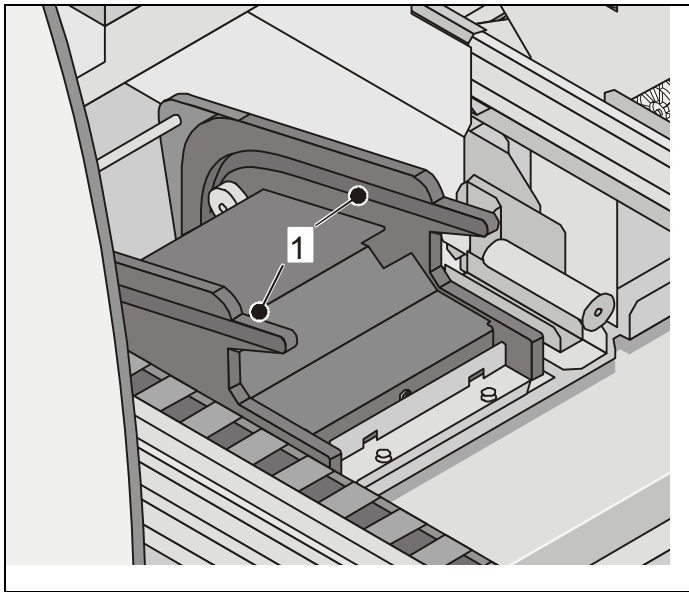

If the clamp has come to a standstill at a position outside the stacking position, you may need to check and clean the gear tracks (1).

- Check the photosensors in the shutter area.

After checking the cash paths, proceed as follows:

- After checking the cash paths push the CMD-V4 by the green release lever back into the safe as far as possible.
- Close the safe door
- Function test

Press the function pushbutton on the CMD-V4 controller to start tests and to reset the CMD-V4. To start a test function, the CMD-V4 must be in normal operating mode. '00' or '14' is then shown on the status display.

When you press and hold the function key, '00', '1', '2', '3', '4' and '5' are shown on the status display. What these numbers mean is described in the following table. To start a particular sequence, release the key when the status display shows the relevant value.



The functions described in the following sections can be performed only when the safety switch is closed (i.e. the CMD-V4 is in cash-out position). Functions '2' and '3' may be started only from normal operation (display '00' or '14') or when all transport paths are guaranteed to be clear.

Display	Function	Function description
00	Normal operation	-
01	RESET	The CMD-V4 is powered up while '—' is displayed on the status indicator (for approx. 10 seconds). If an error is detected which prevents or endangers the operability of the CMD-V4 (soiled photosensors), the relevant error or a warning is displayed on the status display. This test function is identical to the power-up test when the CMD-V4 is pushed into the dispensing position (closing the safety switch).
02	Overall test + RESET	In this test all mechanical CMD-V4 components are operated one after the other. If an error is detected, it is displayed on the status display. The lifting magnets for the single reject switch and retaining shafts and the electromagnetic clutch can only be subjected to a visual function check in this case. If no errors are detected during the test, a RESET is then carried out.
03	Test dispensing + RESET	With this test the cash paths and the dispensing function of all inserted and filled cassettes are checked: First a banknote is extracted from the top cassette and transported via the single reject switch to the reject compartment. Then one banknote is extracted from each cassette, transported by the clamp to the waiting position (the shutter remains closed) and then to the reject compartment. If an error occurs, it is displayed on the status display. If no errors are detected during the function, a RESET is then carried out.
04	Display firmware version	The version number is displayed in alternating mode. Example: In the case of the module label <code>\$MOD\$ 011214 1000 CMD_V4_0.BIN</code> version number <b>1000</b> of the first release on December 14, 2001 is displayed as follows: <b>10</b> for 2 seconds (basic release / upgrade release) <b>00</b> for 1 second (upgrade (expansion) / update (error elimination)) After nine attempts, the device returns to normal mode.
05	Statistics counter reset	The resettable counters are reset to 0 and the current date of the real time clock is saved.

# Coin Dispenser

## Components

The figure identifies the major parts of the Coin Dispenser.

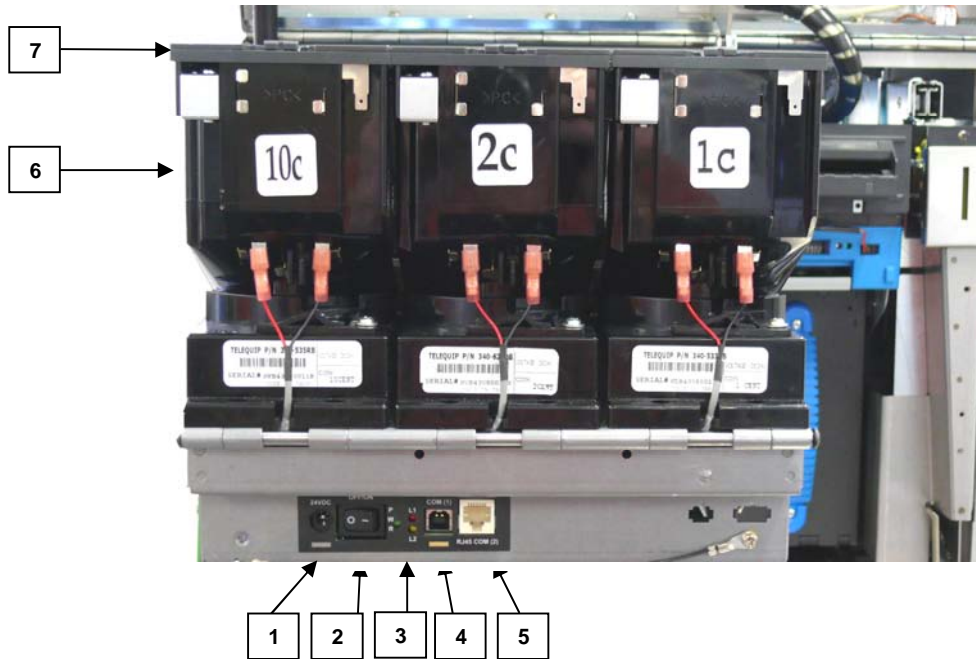

1	DC Power Jack	2	ON/OFF Switch	3	Status lights	4	USB Port
5	RS 232 Port	6	Coin Hopper	7	Hopper Cover		

<b>Coin hoppers</b>	Contains the coin inventory. Coin hoppers are available in models that support several types of coins.
<b>Hopper Covers</b>	A hinged hopper cover encloses the hopper bins. Prevents unwanted coins and debris from entering the hopper during filling and use. Allows a hopper to be tilted while filled with inventory.
<b>Communication ports</b>	USB or RS-232 serial interface connecting to the point of sale device or terminal.
<b>Status lights</b>  Green (constant) Red (constant) Red (blinking) Yellow (blinking)	Power LED. Reports when the device is on and ready. Warning LED. Reports a machine error. Warning LED. There are one or more bins with low coin status. Communication LED. Flashes briefly when valid RS-232 or data flow communications are passed to or from the host.
<b>DC power jack</b>	Receptacle into which the power cable is inserted.
<b>Power switch</b>	Powers the coin dispenser on and off.

### Switching off / pulling out the Coin Dispenser

Unlock the front door and swing it up. Put the key to the lock and turn it to the left to unlock the coin dispenser (1). Seize the green handle in the middle (2) and pull the coin dispenser out completely.



Switch off the coin dispenser (Position 0).



### Slide in / Rotating the Coin Dispenser

Press the green locking and slide in the coin dispenser.

Avoid squeezing your hand!

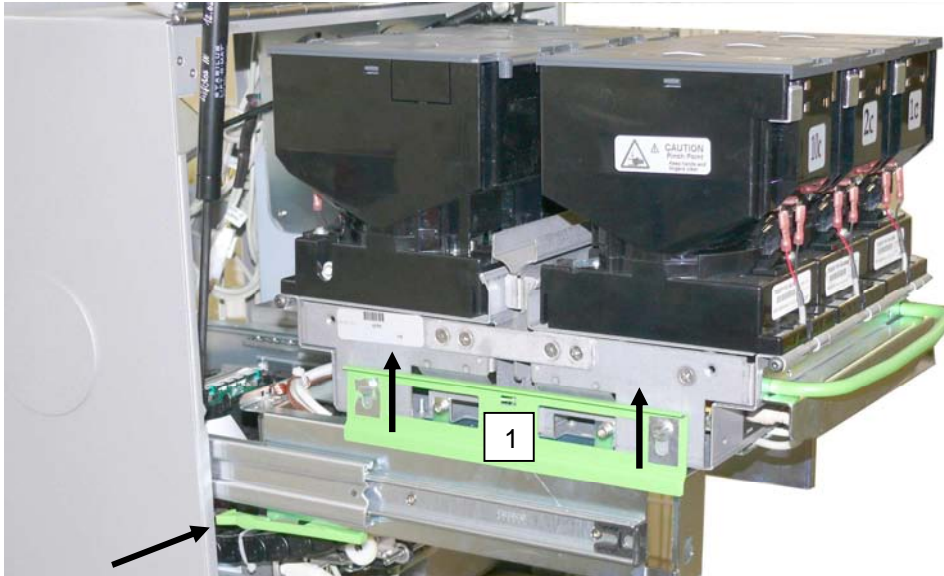

While lifting up the locking mechanism (1) you can turn the coin dispenser 90° to the right.

### Factory Settings

The coin dispenser is configured at the factory according to the customer's specific requests. The following standard options are programmed, unless otherwise specified:

- "Even Depletion" of coins (versus "minimum dispense")
- USB HID device
- Low coin alarm enabled
- Low coin sound enabled

The procedures to change these options are described in the Service Guide. Contact your service provider for assistance.

## Coin Capacity

The coin dispenser US Standard 3 bin dispenser holds approximately €200 in coins.

The high capacity of the coin dispenser assures more transactions between refills. A single US Standard bin configuration can last between 4-5 hours in a high volume sales setting.

- The time between fills will vary, depending on your particular environment. You can perform your own calculations by using the following information:
- Assume an average transaction dispenses 50 cents
- Divide the amount of the coin inventory (in this example, a US Standard 3 bin coin dispenser with €200 in coins) by 50 cents, which yields over 400 transactions between fillings.
- Determine how many transactions per hour are conducted in your operation (for this example, we use 70 transactions)
- Divide the 400 transactions per filling by 70 transactions per hour, which yields 5.7 hours

This example assumes the even depletion option, which is the factory-standard setting.

## Low Coin Modes

Your service technician can set your coin dispenser for any of the following options with the Configure and Test Application, as described in the coin dispenser Service Guide.

As bins start reaching low coin status they will go through cycles of high and low coin. This occurs as coins mechanically move on and off the low coin sensor plates. Eventually, low coin will go low and stay low. A low coin condition is reported by the "low coin status" at all times, no matter how the machine is configured.

## Alarm Sound

If the low coin alarm is enabled, whenever the dispenser is in a low coin condition the speaker will sound in a pulsing rhythm.

## Low Coin Disabled

If low coin is disabled, the coin dispenser will report low coin as each bin goes into a low coin condition. The coin dispenser will never take action on this condition and it is possible to try to dispense from an empty bin.

On low coin conditions the status is reported in the machine status byte. The POS system may take advantage of the low coin report from the dispenser to create a prompt for the user.

### **Low Coin Enabled, Even Depletion Off (Dispense by bin or dispense by amount)**

When any bin of coin drops below a certain level, the low coin alarm will be set (the alarm will sound only if it is enabled). A low coin condition sets a number of allowable coin dispenses (20 coin dispenses is the default setting. This number is configurable) from the low coin bin before the dispenser stops dispensing. Should the low coin condition go away because of the stirring action of the hopper, the allowable dispenses for that bin are reset. A machine that stops dispensing because it has exceeded allowable dispenses after low coin will have an inventory of 10 to 30 coins in the bin. To silence the alarm, turn the power switch off. Refill the coin dispenser and then turn the power back on.

If the coin dispenser is powered up with any of the bins in a low coin condition, it will not dispense coins until power is cycled with all bins above the low coin level.

### **Low Coin Enabled, Even Depletion On (Dispense by amount)**

When the first bin reports a low coin condition, the red LED will start to flash and the alarm will sound (if enabled). The dispenser will continue to operate until the coin inventory is insufficient to satisfy the 'dispense below value.' After this has been reached the red LED will turn solid, dispensing will be disabled and the alarm will change to a constant tone (if enabled).

On low coin conditions the status is reported in the machine status byte. The POS system may take advantage of the low coin report from the dispenser to create a prompt for the user.

### **Dispense History**

A history of coins dispensed is stored in volatile memory. A separate count is stored for each bin. Cycling power or issuing a 'clear history' command will clear history.

The POS system may request history in one of two ways. Coins used from each bin may be reported after each dispense or reported as accumulated from the last reset. The POS system must manage this information.

### **In System Programming**

Firmware upgrades can be flashed directly through the RS-232 or USB port with use of a Telequip upgrade utility.

### **External Power supply**

The Coin dispenser coin dispenser is supplied with a UL listed 24V, 40W external switch mode power supply. Only UL listed supplies with similar ratings may be used to power the Coin dispenser.

### **Power Cable**

The cable that connects the coin dispenser to the source of electrical power is detachable, and available in several terminations to match local power receptacles.

## Communications Cable

**RS- 232** -- A standard RS-232 serial cable is used to connect the coin dispenser to the point of sale (POS) device. The cable end that plugs into the coin dispenser is terminated with an RJ-45 connector. The other end of the cable is typically fitted with a DB-9 female connector; however, other connectors may be requested when placing an order.

**USB** -- A USB 1.1 Standard A to B cable is used to connect the coin dispenser to the point of sale (POS) device or teller system.

## Filling the Coin Dispenser

Unlatch and open the hopper cover to the denomination you want to fill. Load coin and close the hopper cover. Move on to the next denomination. Power on the dispenser when filling is done.

## Emptying the Coin Dispenser

Start on page 39. Lift up the green bar on the left side of the dispenser (1) and rotate it to the left by 90°.

Avoid squeezing your hand!

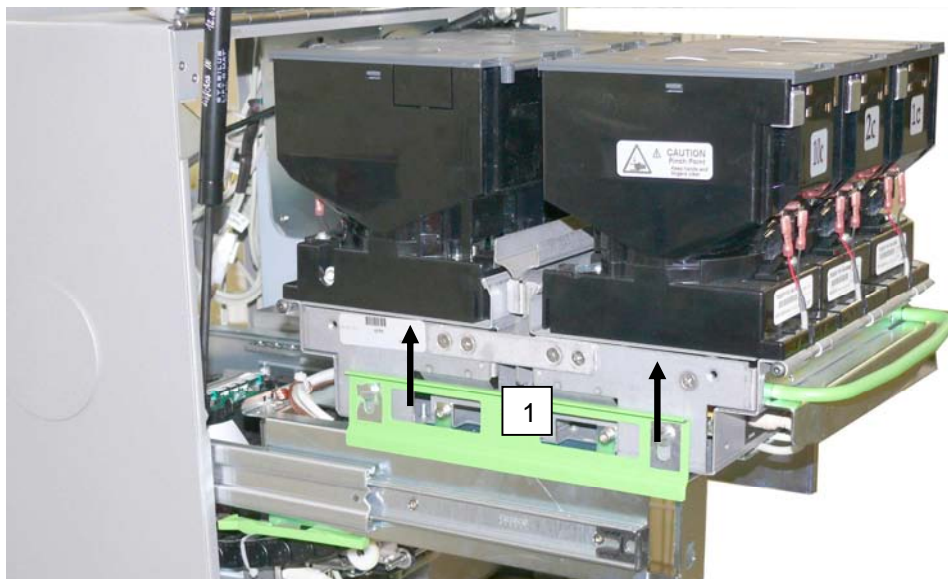

Unlatch and open the hopper cover to the denomination you want to empty.



Position a container to the side of the hopper being emptied. Hold the hopper firmly and rotate about the hinge so coin fall into the container.

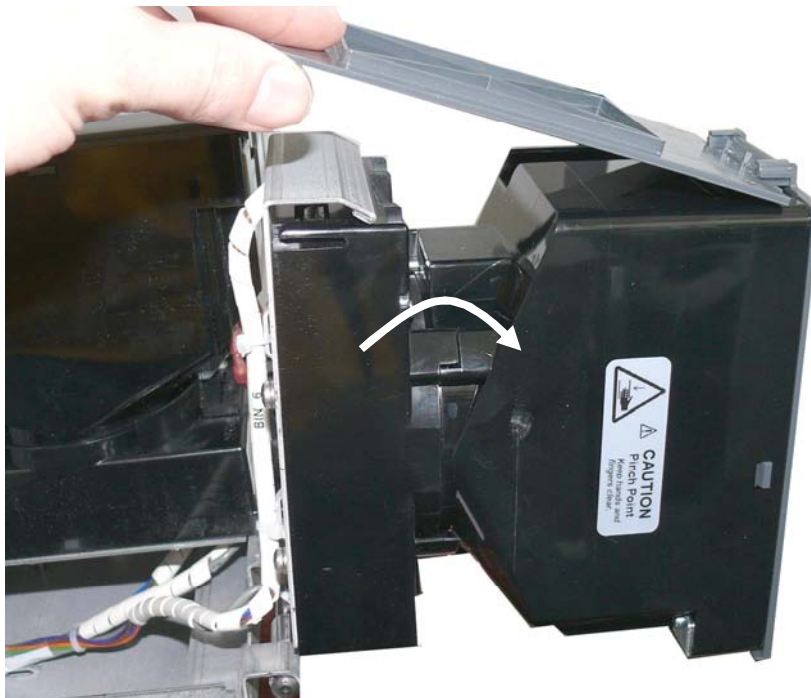

Rotate hopper back to starting position. There may be several coins remaining in the hopper, which may be cleared by issuing the audit dump command. Care should be taken to keep fingers clear of the hinged chassis panels when dumping coins.

## Clearing a Coin Jam

Occasionally there may be a coin jam that cannot be resolved by the auto reversing of the coin hopper. There are two methods to correct a jam.



The majority of jams can be cleared by manually rotating the hopper rotor. To accomplish this, first issue the fault by hopper command to query the dispenser and identify which hopper is jammed. Then power down the unit. Tilt the jammed hopper back to reveal the mechanical screw on the side of the hopper base.

Use a Phillips screwdriver and rotate the screw clockwise (oriented so screw is facing you and the coin ejection side of the hopper is to your right) until the jammed coin moves past the hopper ejector pin. Do not apply excessive force to the plastic screw head or it will strip. See section below for jams that cannot be cleared by this method. Care should be taken to keep fingers clear of the hinged chassis panels when rotating the hoppers.



If the mechanical screw is not easily turned, the hopper must be disassembled to free the jam. Once the jammed hopper has been identified and the dispenser is powered down, open the hopper cover and dump the coin inventory.

Disconnect the 2 low coin terminals on the back of the hopper bin. Facing the coin ejection side of the hopper, rotate hopper bin counter clockwise and remove. Pull rotor straight up to remove. Remove the jammed coin and reinsert rotor. Place hopper bin into position and rotate clockwise until it snaps into position. Reattach the 2 low coin terminals.

## Maintenance



The coin dispenser is designed to be low maintenance. It is important to keep the coin dispenser clean. Use only a soft, damp cloth to remove surface dirt.

The unit does NOT need to be oiled. Using oil, detergents or petroleum-based cleaning compounds can adversely affect the reliability of the coin dispenser.

### Trouble Shooting

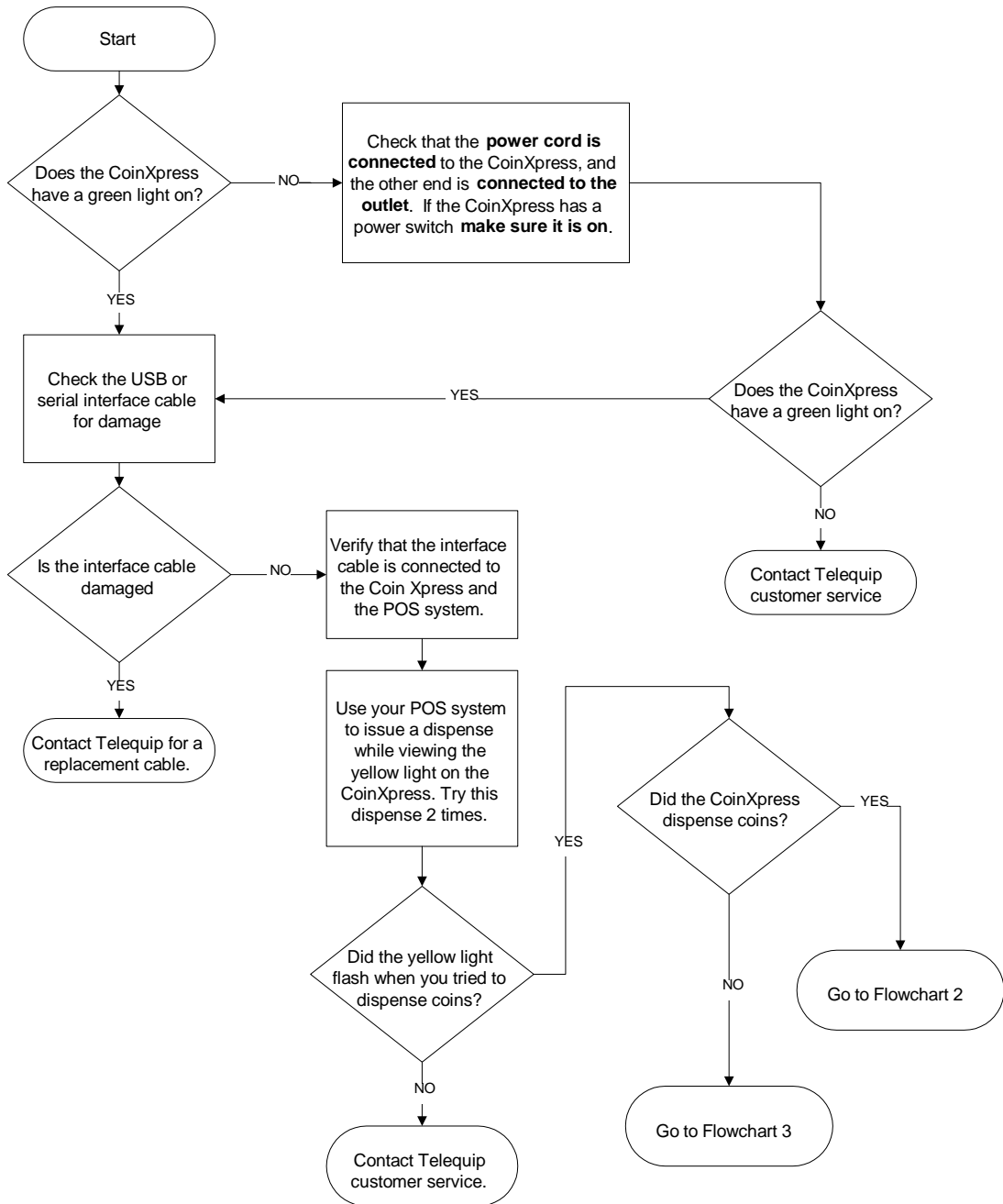

### CoinXpress Troubleshoot Flowchart 2

If the CoinXpress dispenses coins start on this page, otherwise start on page 1

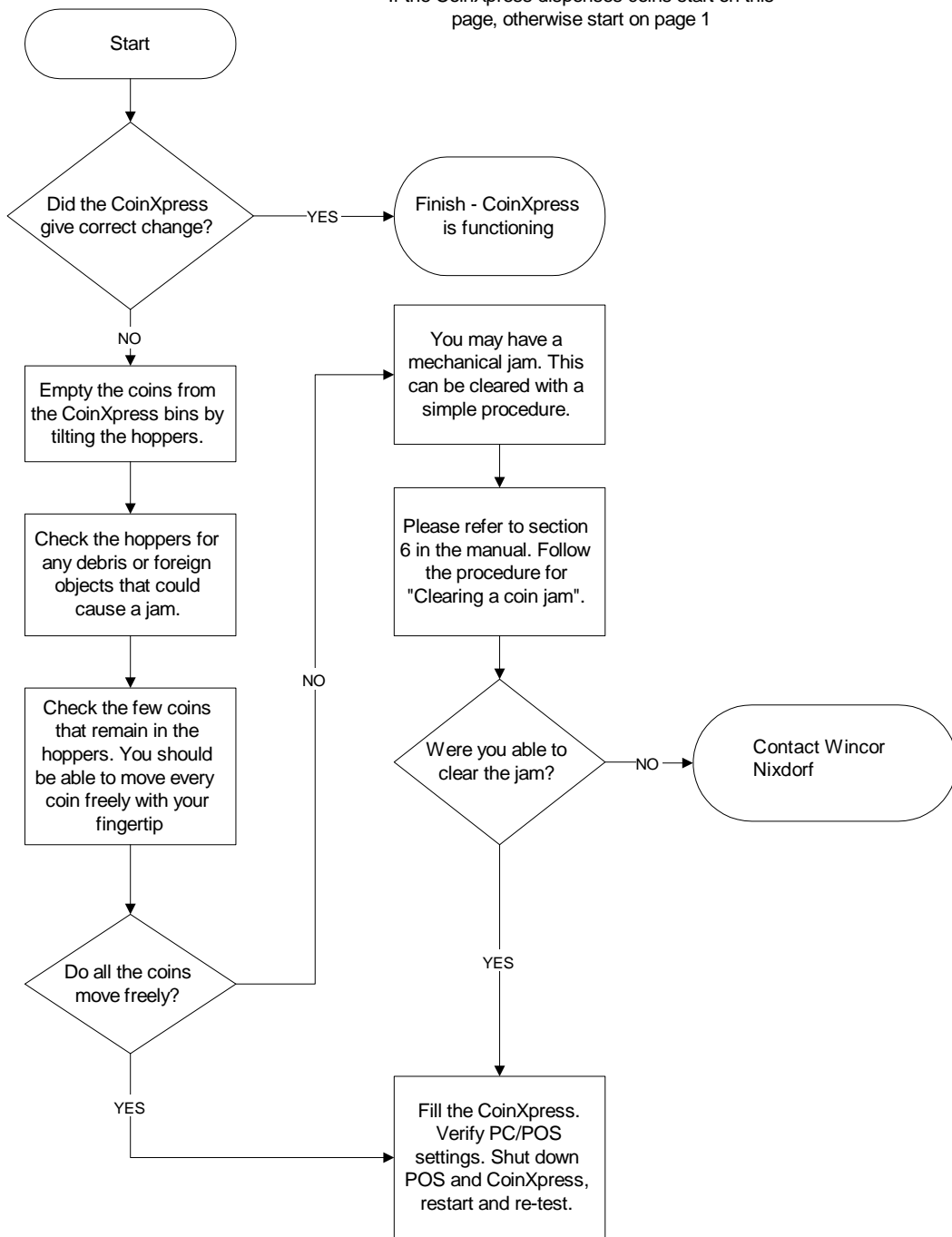

## Specifications

<b>Size:</b>	13 1/2" W x 9" H x 14-1/4" L
<b>Weight:</b>	21 lbs. – 6 bin without coin 65 lbs. - 6 bin with coin
<b>Power:</b>	24 Volt DC, 2 Amps max. 120 to 240 VAC, 50 or 60 Hz 24V external switch mode power supply
<b>Power Consumption:</b>	40W
<b>Power Cord:</b>	Detachable power cords with different terminations to match local power receptacles, and in different lengths, are available.
<b>Communication Cable:</b>	Cables with various serial cable terminations and in different lengths are available.
<b>Operating Temp. Range:</b>	0° - 40°C
<b>Humidity range:</b>	+0 to 80% RH and non-condensing
<b>Certifications:</b>	CE, UL, CUL, FCC

## Coin Input

### Correcting a coin jam

Unlock the front door and swing it up. The coin input is located beside the bank-note input.

Grab the coin input (1) and pull it out completely.



Correct the coin jam by pressing the mechanism (1) so often until the coin falls into the box.

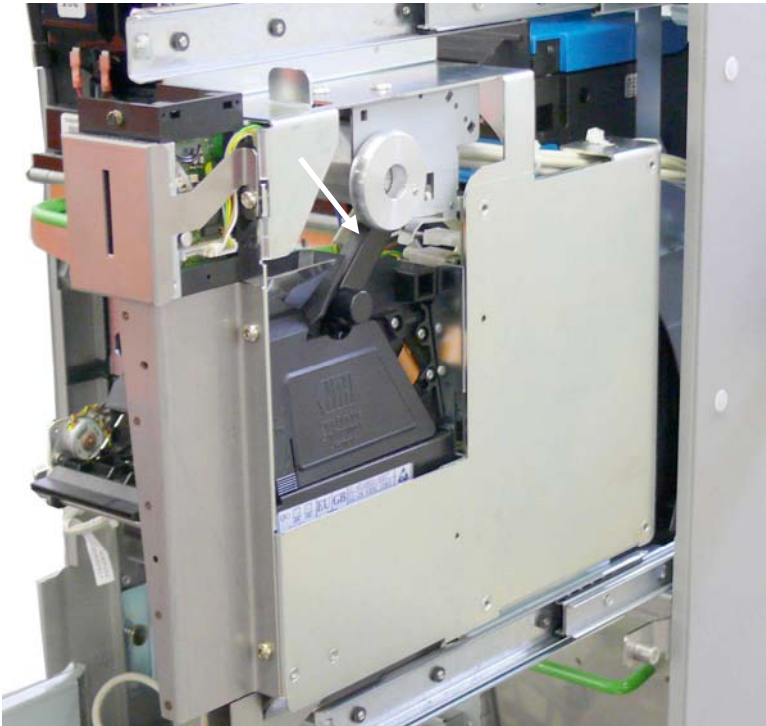

If this doesn't work, press on the button (1) and open the coin input. You can remove the coin. Close it only by pressing the button (2). Otherwise it is possible to damage the coin input module.



## CMD V4-Shutter

The CMD V4-Shutter is located in the bottom door.



### Introduction

The shutter locks the cash output tray of the cash media dispenser (CMD-V4). It includes the following assemblies: Drive mechanism with stepper motor, gears, locking mechanism, and two hybrid photosensors (GL 10 and GL 11) for monitoring the position of the shutter

1 photosensor (LS 28) for providing a cash bundle for output

1 photosensor (LS 27) for monitoring removal of cash

1 Interface board for controlling the shutter

## Function

The shutter is controlled via the firmware of the CMD-V4 controller and is initiated by the application software.

Shutter and drive mechanism are directly connected. The rotation of a cam disk makes the shutter open and close. The stepper motor has low motive force so there is no risk of injury when the shutter is closed.

The shutter is locked automatically when it is completely closed.

## Cash removal

If the application sends an order to dispense cash, the shutter is first opened completely via the firmware. After the banknotes have been transported into the position where they can be removed, the shutter is partly closed depending on the thickness of the banknote bundle. The thickness of the bundle is detected by the thickness measuring unit in the CMD-V4. The value that is identified is used to control the drive motor for a limited time.

When the cash has been removed the shutter is first opened completely via the firmware and the drive belts in the transport gripper are briefly moved backward. Then the shutter is closed completely and locked unless this is prevented by external influences.

## Error code 28

If the shutter does not close within approx. 1 second, the firmware turns the motor off, generates an error code (error code 28 displayed on the CMD-V4 controller) and reports the error to the application.

Error code 29 (protection against tampering)

Error code 29 is displayed if photosensor LS 27 is covered when the shutter is closed. The firmware tries to close the shutter anyway. The motor is turned off if that does not succeed within approx. 1 second.

## Single Banknote Validator

The single banknote validator is a component that is used to implement a payment function with banknotes.

Payments are made by inserting individual banknotes in the banknote input slot.

The banknote is centered automatically, tested in the validator unit and, if it tests positive, is sorted and conveyed by the transport unit to a cash box, where they are stored. Alternatively, if the test is not positive, they are returned to the output tray.

Unlock the front door and swing it up. The banknote validator (1) is located beside the coin machine.

Unlock the Note Box by turning the key to the left (2). Remove the box forward to empty it.



### Function elements and controls

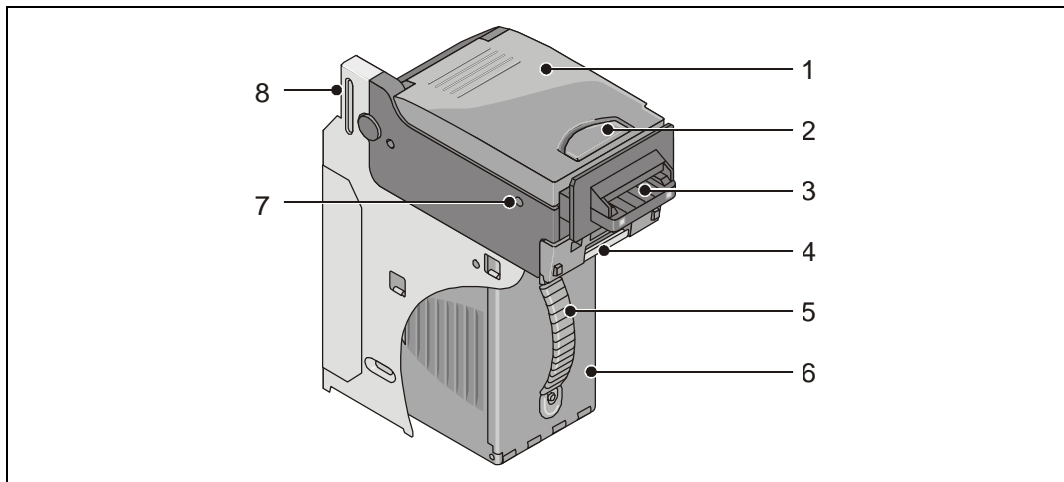

1	Validator unit	5	Box handle
2	Release lever of validator unit	6	Cash box
3	Banknote input slot	7	Emergency release of validator unit
4	Release lever of transport unit	8	Combined power and data interface

### Validator unit

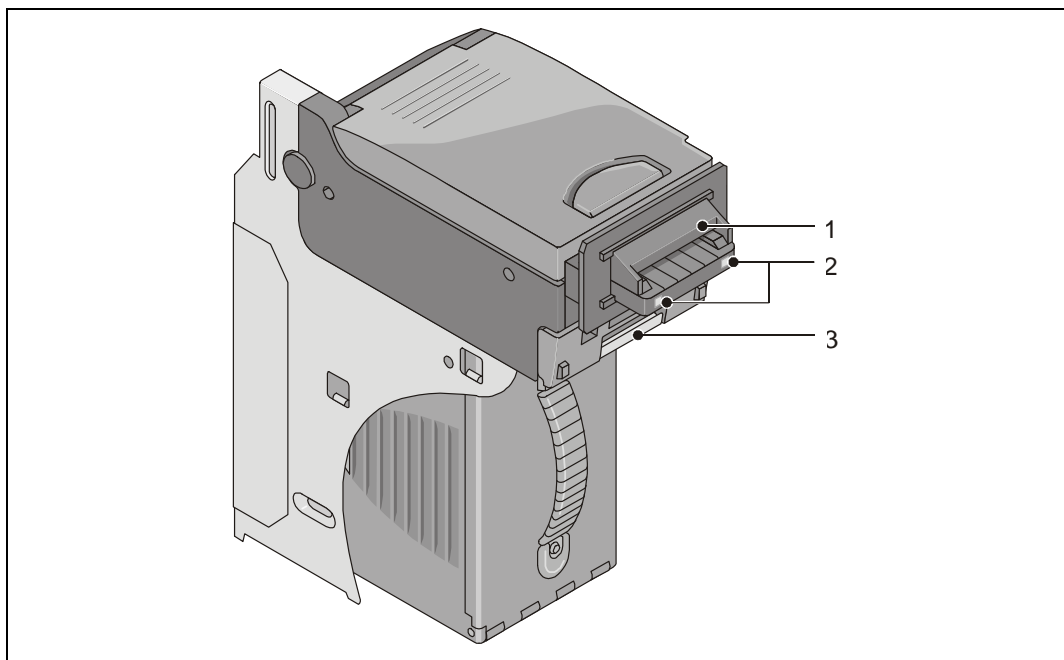

1	Faceplate	3	Release lever of transport unit
2	Ready indicators		

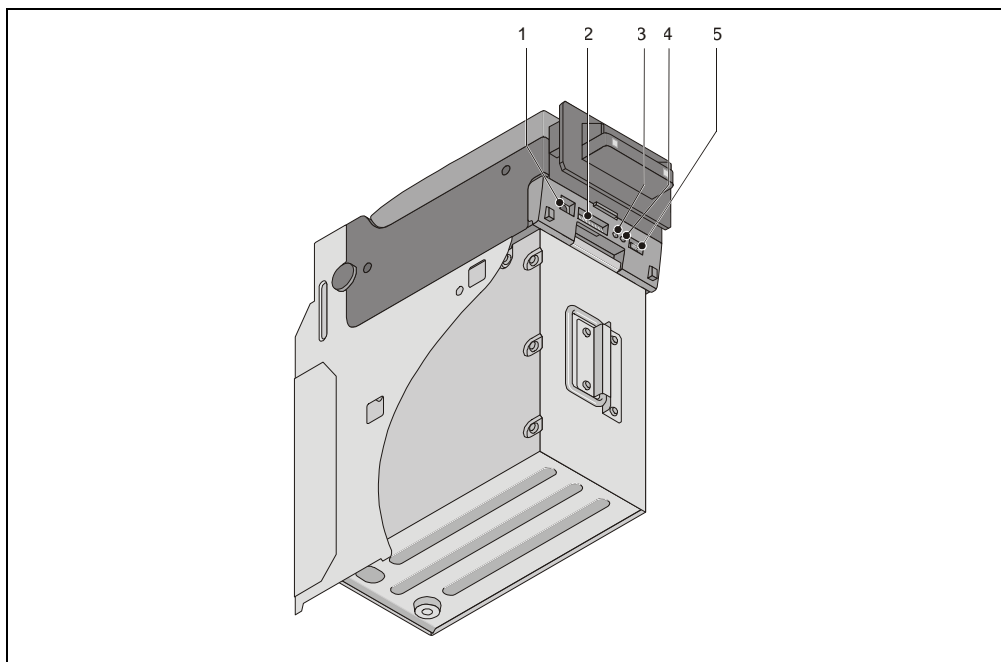

1	USB port	4	Green status LED
2	DIP switch	5	Faceplate connector
3	Red status LED		

### Cash boxes

The cash boxes serve to store inserted banknotes. There are two different cash boxes depending on the version used. The cash boxes differ in the material they are made of and their size.

Material	Capacity		
Plastic:	500	banknotes	
Steel:	900	banknotes	

#### Cash box for 500 banknotes

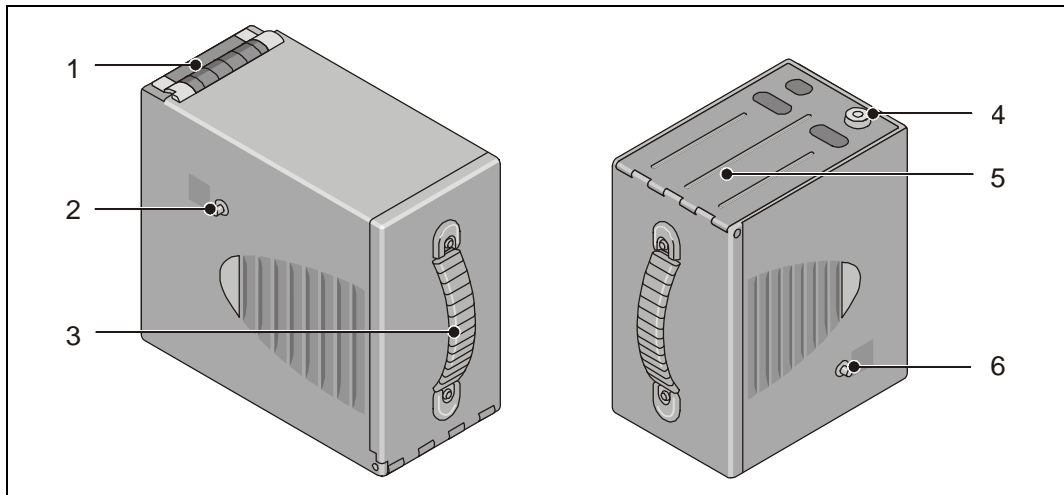

1	Note input	4	Box lock
2	Guide bolts	5	Box lid
3	Box handle	6	Guide bolts

#### Cash box for 900 banknotes

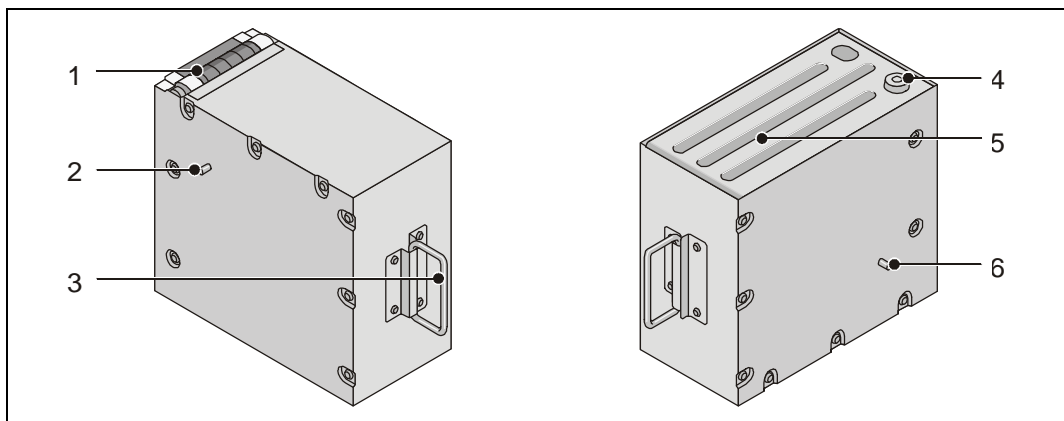

1	Note input	4	Box lock
2	Guide bolts	5	Box lid
3	Box handle	6	Guide bolts

## Removing / inserting the cash box



Removing and inserting the cash box is shown for a 900-note cash box as an example. The procedure is the same for 500-note cash boxes.

Open the device and pull out the single banknote validator (see chapter "Basic Operation", section "Opening / closing the device").

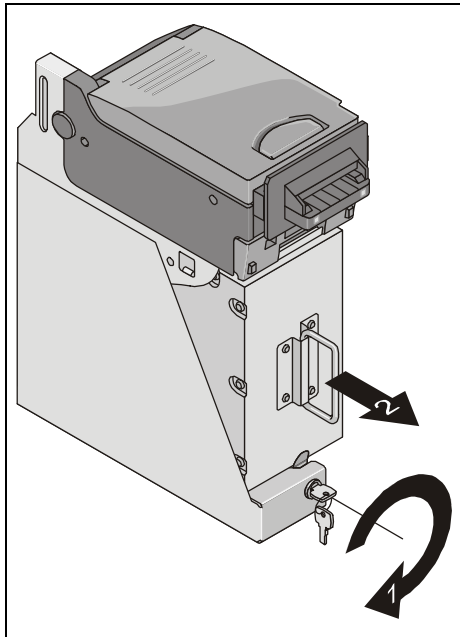

### Removing it

Insert the key in the lock (1) and turn it as far as possible in the direction of the arrow (1). Pull the box out of the device by the handle (2) in the direction shown by the arrow. Support the box with one hand.

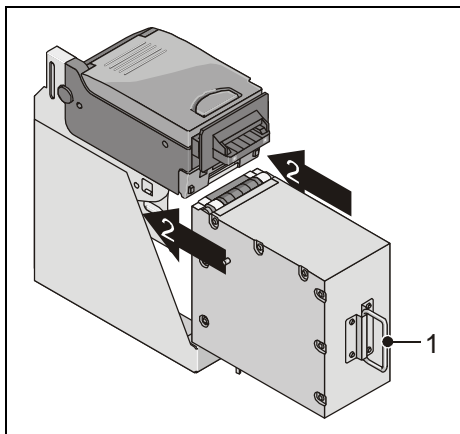

### Inserting it

Holding the box by the handle (1) push it in the single banknote validator in the direction shown by the arrow (2). Make sure that the guide bolts (at left and right on the box) are positioned correctly in the respective mountings in the housing. Push the box in as far as possible.

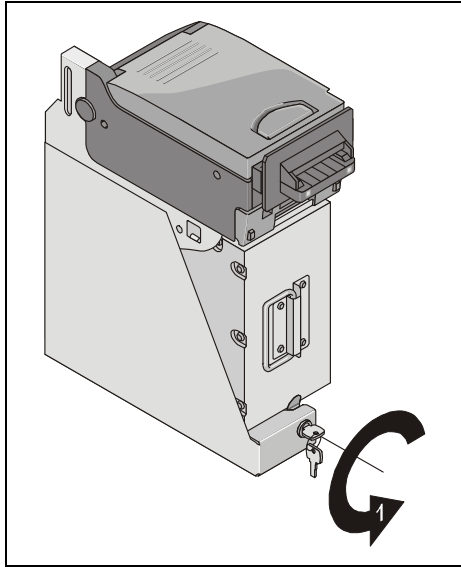

Insert the key in the lock (1) and turn it as far as possible in the direction of the arrow (1) and pull the key from the lock.

Push the single banknote validator in the device as far as possible and close the device (see chapter "Basic Operation", section "Opening / closing the device").

### Opening / closing the cash box

**i** Opening and closing the cash box is shown for a 500-note cash box as an example. The procedure is the same for 900-note cash boxes.

Remove the box from the single banknote validator (see section "Removing / inserting the cash box").

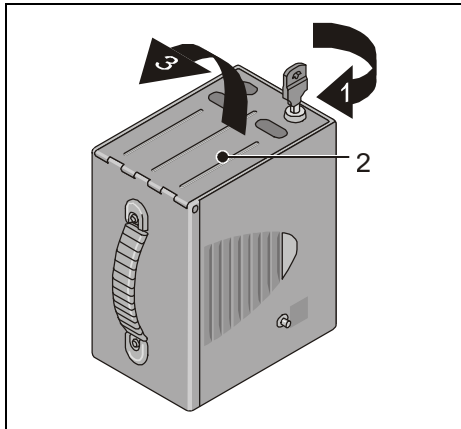

#### Opening it

Insert the key in the lock (1) and turn it as far as possible in the direction of the arrow (1). Open the box lid (2) in the direction of the arrow (3).

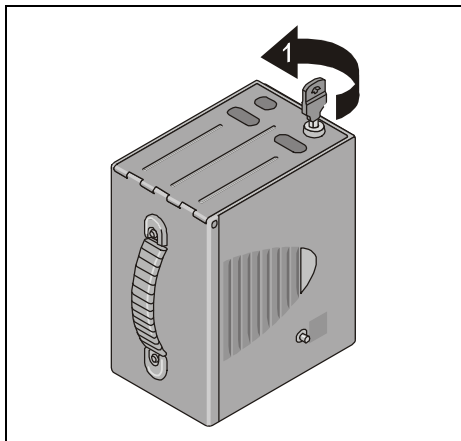

#### Closing it

Shut the box by lowering the lid. Insert the key in the lock (1) and turn it as far as possible in the direction of the arrow (1) and pull the key from the lock.

### Emptying the cash box



Emptying the cash box is shown for a 500-note cash box as an example. The procedure is the same for 900-note cash boxes.

Open the cash box (see section "Opening / closing the cash box").

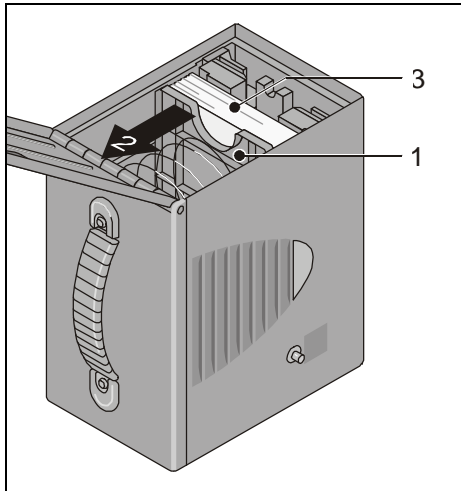

Push the slide (1) a little in the direction of the arrow (2) and remove the banknotes (3) from the box.

Close the cash box (see section "Opening / closing the cash box") and insert it.

### Description of the banknote path

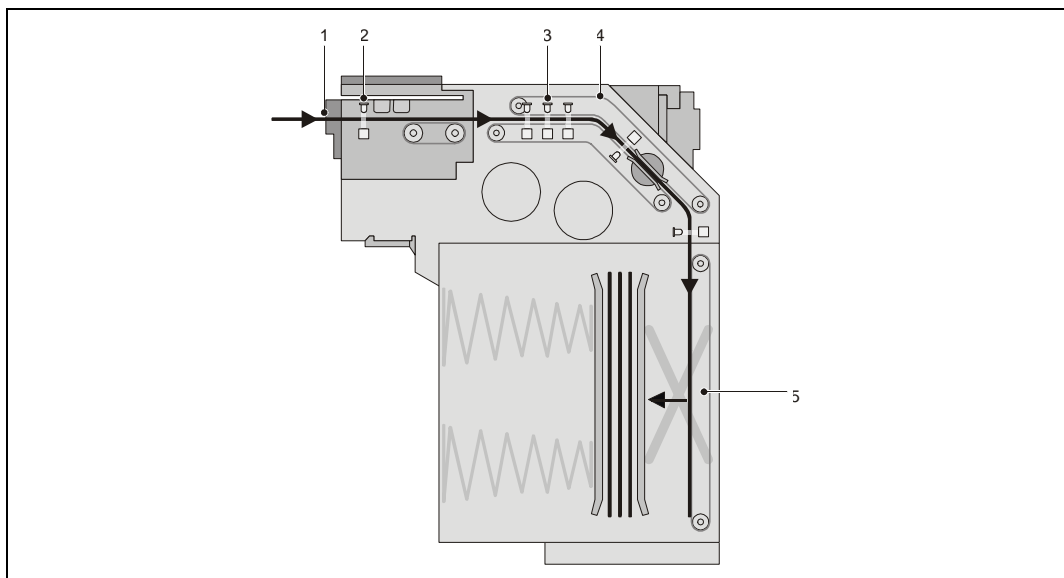

1	Banknote input slot	4	Transport unit
2	Validator / centering unit	5	Cash box
3	Validator unit		

- The banknote you insert in the banknote input slot is centered and conveyed to the validator unit.
- Counterfeit notes and notes that are not identified are returned to the banknote input slot for removal.
- Banknotes that are identified as genuine are conveyed to the cash box by the transport unit.

## LEDs

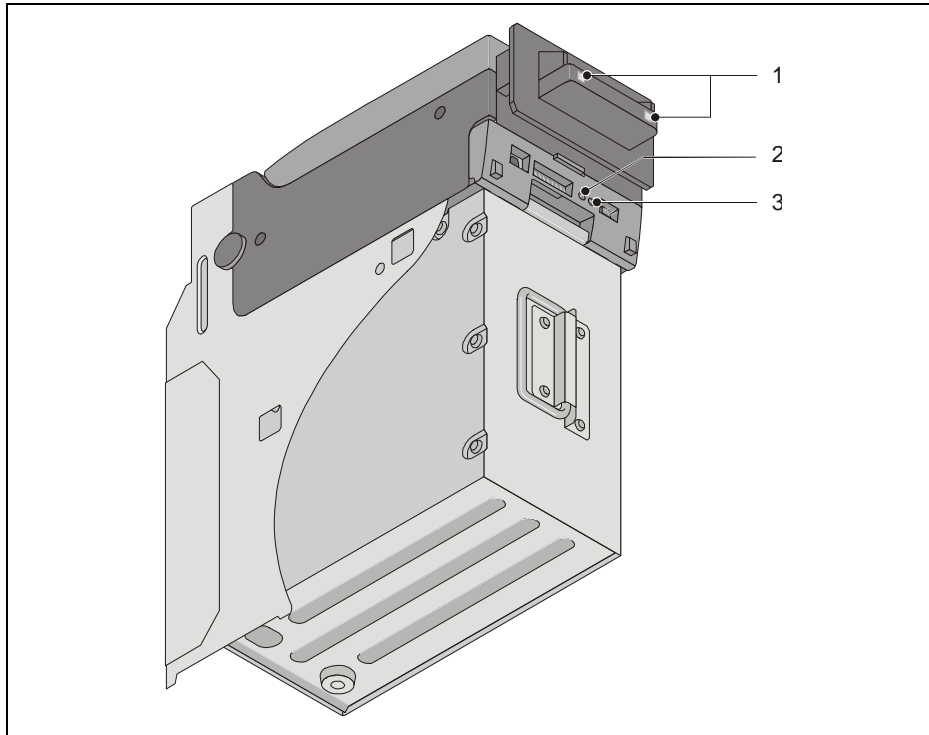

1	Ready LED green	Off:	Banknote validator not ready for operation
		On:	The banknote validator is ready, a banknote can be inserted.
2	Red status LED	The status LEDs indicate possible malfunctions and rejects (see also section "Optical signals").	
3	Green status LED		

## Optical signals

### General

When an error occurs, a status LED blinks, e.g. red 3 times briefly; the green status LED may stay lit. After a few seconds the cycle is repeated (see diagram "Example with 3 blinks").

This is repeated until the cause of the error is eliminated.

### Example with 3 blinks

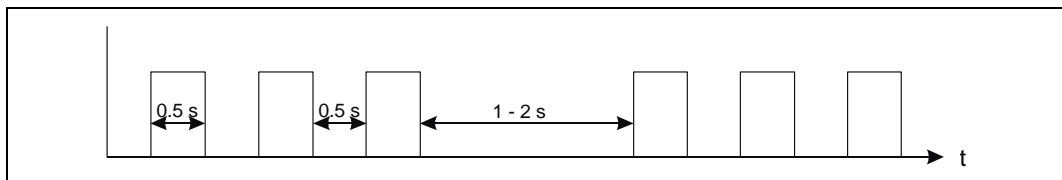

### LED status

Abbreviation	Status
0	LED is off
1	LED is on permanently
3x bl	LED blinks three times

## Cleaning and maintenance



Always switch the device off before cleaning it (see user guide).



Do not use alcohol or solvents for cleaning since the sensor lenses could lose their transparency.

### Cleaning card



The single banknote validator comes with a cleaning card (01750127607). The cleaning card can only be used 4 or 5 times and must then be discarded.

If the acceptance rate for one or more banknote types drops, clean the single banknote validator using cleaning card (01750127607).

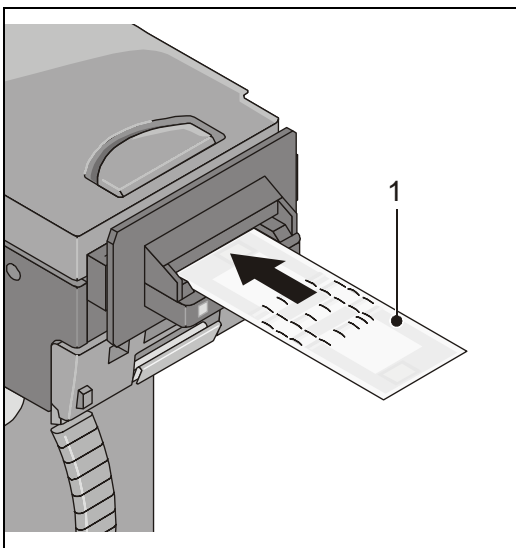

Insert the cleaning card (01750127607) (1) in the single banknote validator in the direction of the arrow. The single banknote validator draws the cleaning card in automatically and cleans the validator. When cleaning is finished, the card is ejected. Repeat this procedure with the same cleaning card 3 to 4 times.

If the acceptance rate is not improved after cleaning, calibration of the single banknote validator must be performed (see section "Autocalibration").

### Validator unit

Switch the device off (see chapter "Basic Operation", section "Switching the device on/off" in the operating manual).

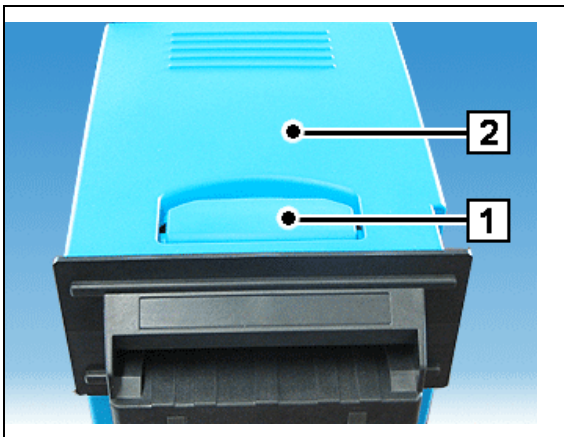

Pull release lever (1) of the validator unit upwards and raise the upper part of the validator unit (2) to the rear.

If the validator unit cannot be opened, you can use the emergency release option (see section "Emergency release for validator unit").

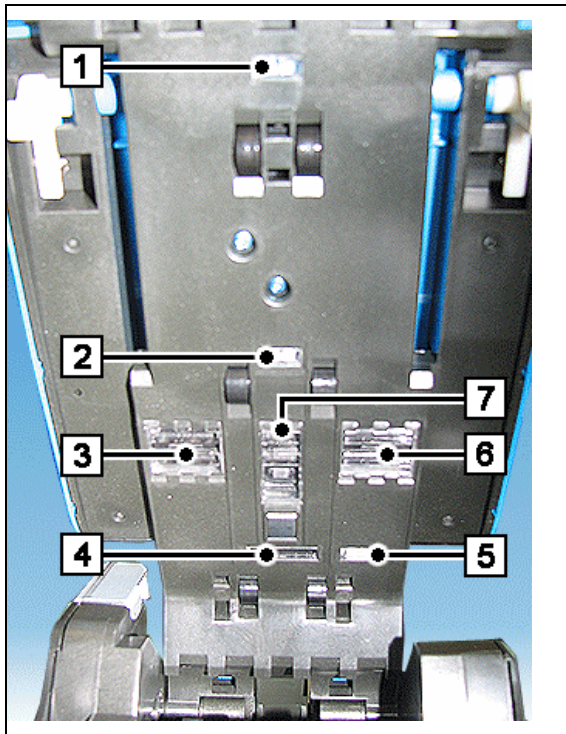

Clean sensors (1) to (7) in the movable part of the validator unit using Wincor Nixdorf cleaning wipes and an air duster.

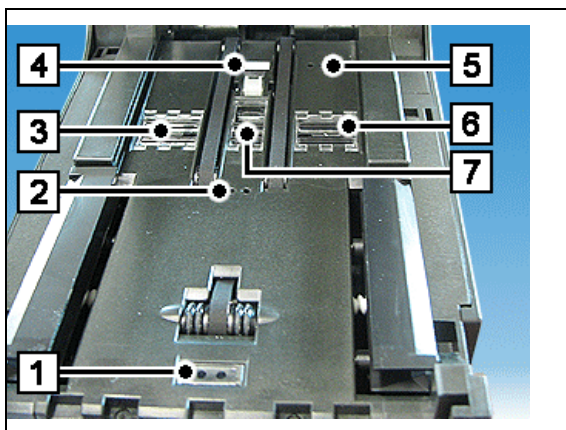

Clean sensors (1) to (7) in the fixed part of the validator unit using Wincor Nixdorf cleaning wipes and an air duster.

Remove paper scraps, dust and foreign objects in the area of the validator unit using tweezers or a brush.

Lower the validator unit until it locks into place.

Calibrate the sensors (see section "Autocalibration").

### Lower section of the single banknote validator



Before removing the validator unit of the single banknote validator switch the device off and disconnect it completely from the power supply (see chapter "Introduction", section "General power interrupt").

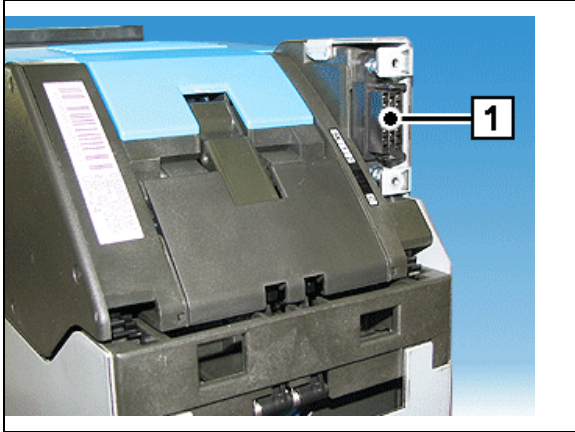

Detach the connector from the socket (1) at the rear of the single banknote validator.

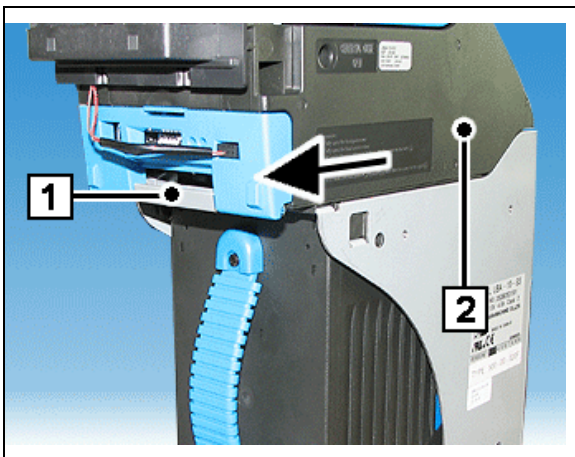

Push the release lever (1) of the transport unit down and detach the validator unit in the direction of the arrow (2) ...

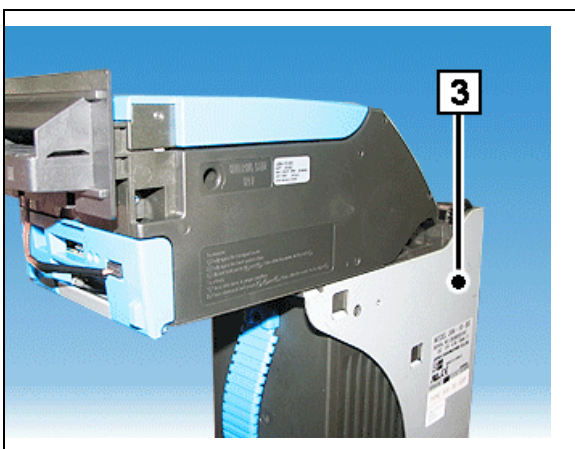

... from the lower section (3) of the single banknote validator.

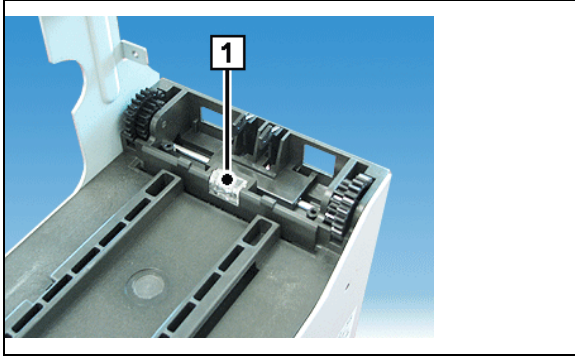

Clean the sensor (1) using Wincor Nixdorf cleaning wipes and an air duster.

Remove paper scraps, dust and foreign objects in the area of the banknote slot. using tweezers or a brush.

Following the reverse order of steps, push the validator unit onto the lower section of the single banknote validator.

Calibrate the sensors (see section "Autocalibration").

#### Transport rollers and transport belts

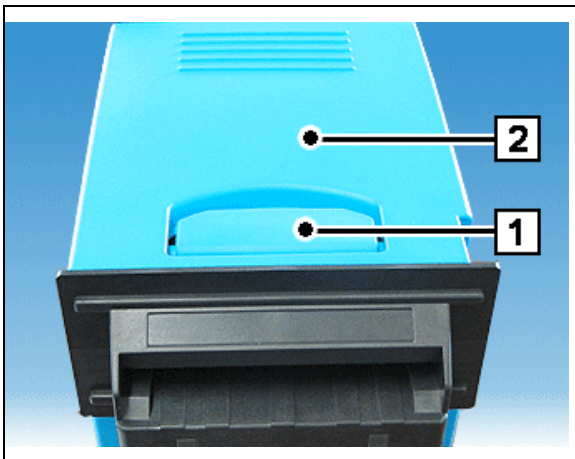

Pull release lever (1) of the validator unit upwards and raise the upper part of the validator unit (2) to the rear.

If the validator unit cannot be opened, you can use the emergency release option (see section "Emergency release for validator unit").

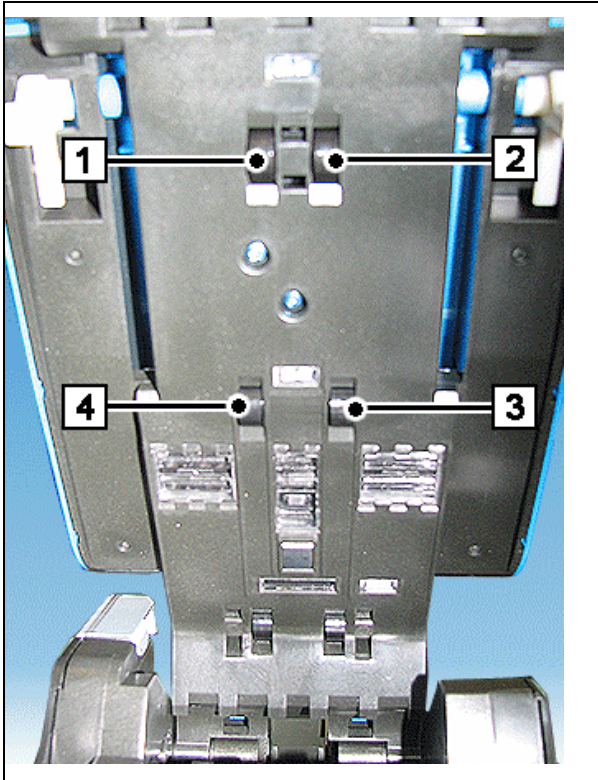

Clean transport rollers (1) to (4) in the moveable section of the validator unit, ...

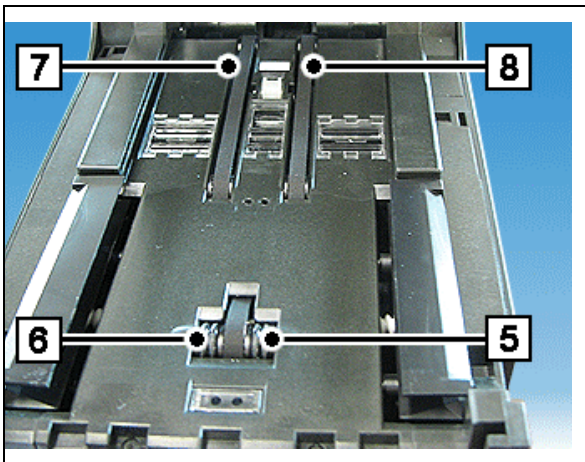

... transport rollers (5) and (6) in the fixed section of the validator unit, and transport belts (7) and (8) using Wincor Nixdorf universal cleaning wipes and an air duster.

Lower the validator unit until it locks into place.

Calibrate the sensors (see section "Autocalibration").

## Autocalibration

Autocalibration is required when banknotes that are inserted are frequently, or always, returned. Either all banknotes or only one denomination, e.g. only €5 notes, are rejected. If autocalibration does not improve the acceptance rate, the single banknote validator must be replaced (see Service Manual chapter "Removal/Installation of Components").

The reference paper 'KS069 Reference Paper Quick Adjustment UBA' (0175127604) is a single-use document that is used for calibration purposes.

- i** DIP switch no. 8 switches 'Test Mode' on the single banknote validator on or off. This is independent of the currency file that is currently loaded.  
 DIP switch no. 8 OFF: 'Test Mode' deactivated  
 DIP switch no. 8 ON: 'Test Mode' activated

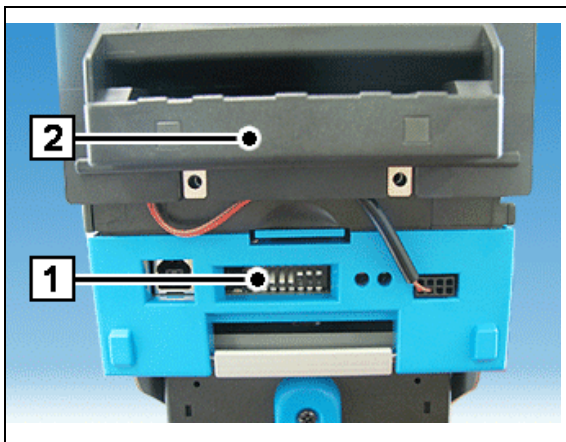

On DIP array (1), set DIP switches 5, 6, 7 and 8 to ON.

Remove the faceplate (2) upwards out of the device and switch the device on.

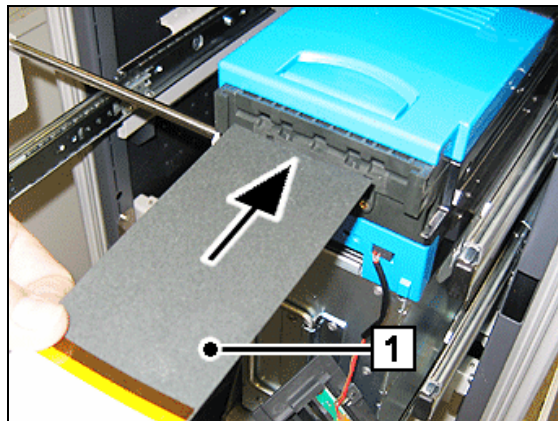

Insert reference paper (0175127604) (1) in the single banknote validator in the direction of the arrow.

The single banknote validator draws the note in automatically and performs calibration. Once the calibration process is over, the document is output.

Successful calibration is shown when the green status LED blinks. If the red status LED blinks, calibration was not successful, switch the device off, check the sensors, and repeat the calibration process.

Switch the device off, set all DIP switches to OFF and switch the device on.

Mount the faceplate in the appropriate mounting on the validator unit.

## BEETLE /M-II

The BEETLE /M-II controls several devices in the BEETLE POS Tower 100 Scan&Bag, such as printer and scanner.

The BEETLE /M-II is located behind the scanner carriage. To remove the BEETLE /M-II you have to remove the scanner.

Switch off the system. Unlock the front door and swing it up.



It is possible to remove the back cover of the POS Tower 100 Scan&Bag to switch of the BEETLE /M-II directly on the box.

**Front view**

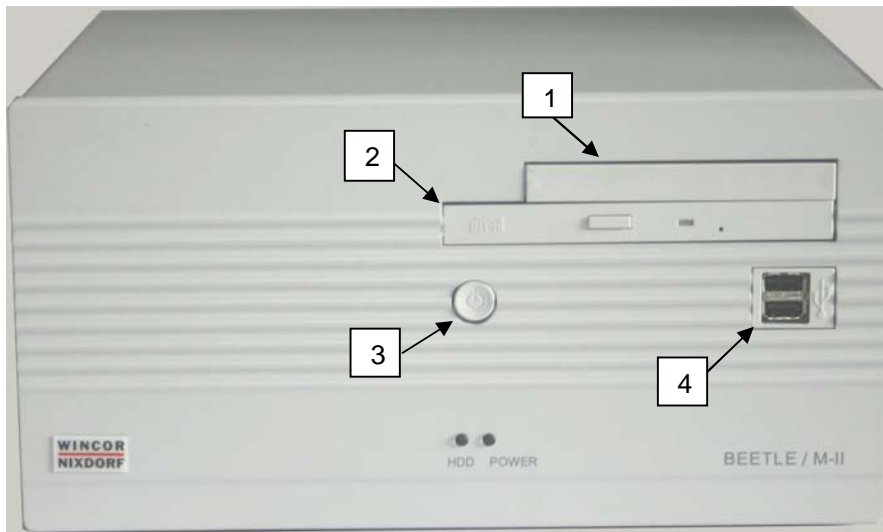

1	Floppy Disk (optional)	2	CD ROM
3	ON-OFF Button	4	USB (2x)

**Inside view**

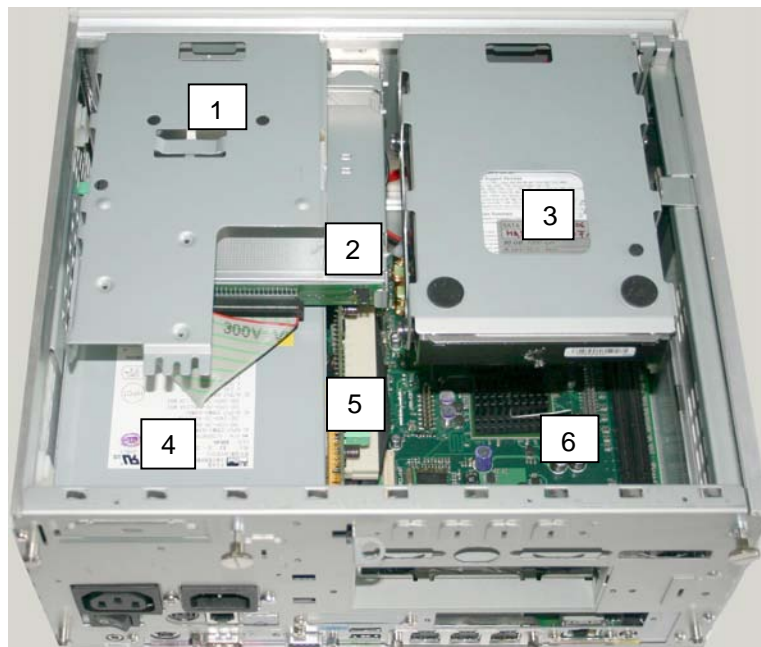

1	Floppy Disk (optional)	2	CD ROM
3	Hard Disk	4	Power Supply
5	Riser Board	6	Motherboard with Processor

**Back view**

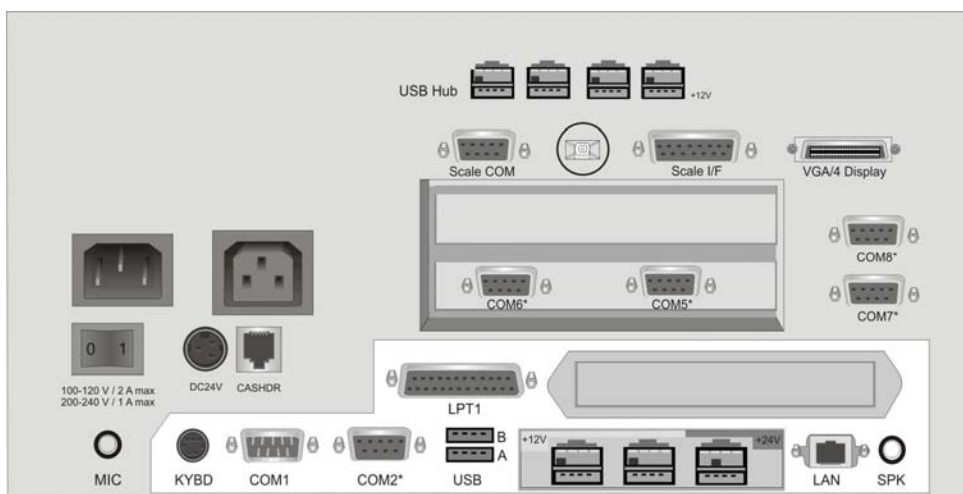

Find the PIN connection in the manual for your mother board.

## Central USB Special Electronics Module

Unlock the front door and swing it up. The USB Special Electronic is located underneath the printer of the POS Tower Line 100 Scan&Bag. Unlock the front door and swing it up.

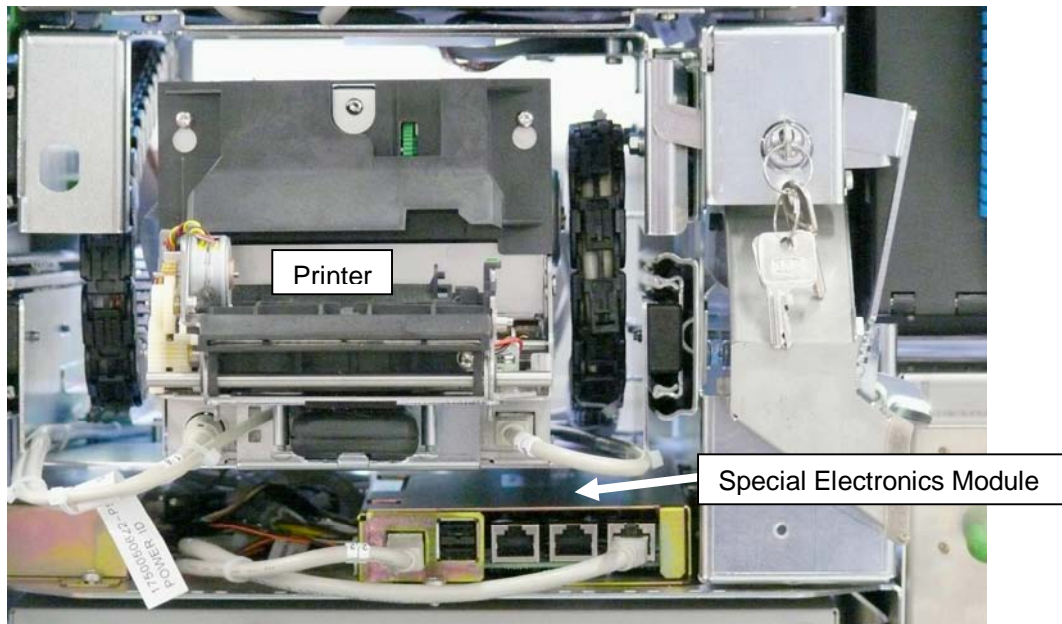

The central USB special electronics module represents, in addition to the built-in PC, the central control and monitoring unit of the system and is connected to the PC via the USB port.

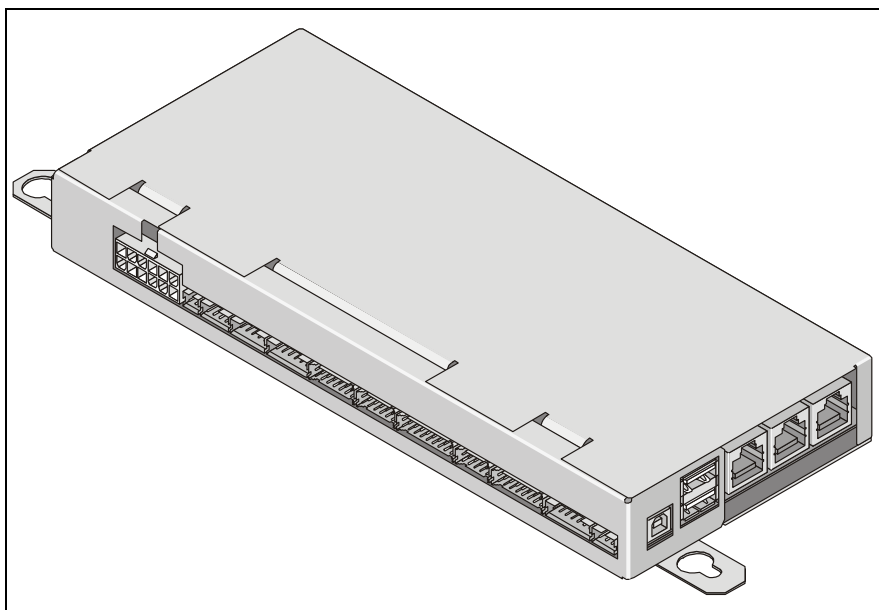

The central USB special electronics module handles functions in the self-service system which have not been assigned to any other typical components for printing, scanning, cash management, customer identification and the like.

An external control unit featuring controls and indicators and up to two customer panel special electronic modules can be configured for the central USB special electronics module.

The functions of the external control unit are also incorporated in the USB operator panel. An additional external control unit is not allowed to be installed in system configurations that are fitted with an operator panel.

The two assemblies customer panel special electronics module and external control unit (also the version integrated in the operator panel) are operated via the I<sup>2</sup>C bus. Power is supplied to these components via the I<sup>2</sup>C bus.

**i** The connectors of the I<sup>2</sup>C ports may only be attached and detached when the device is disconnected from the power supply.

Improper handling can cause complete damage to the components.

Separate descriptions are available in system-specific service manuals for the operator panel, customer panel special electronics module and external control unit.

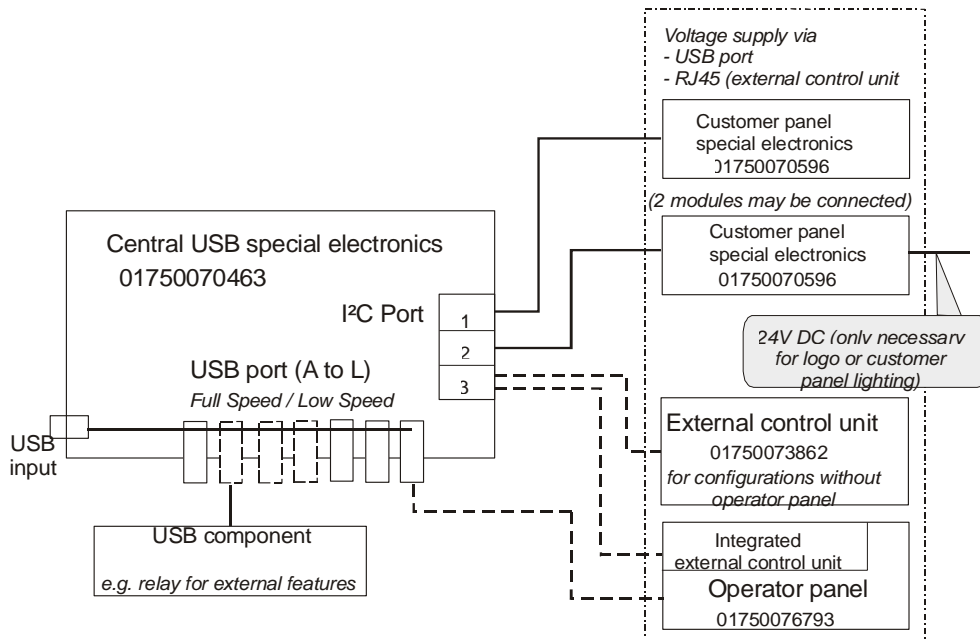

### Functions of the special electronics

- Emergency mode
- Acoustic signal generation
- Control of the first and second customer panel special electronics modules
- Control of the external control unit

- Control of media entry indicators (MEIs)
- Switch-on/off logic for 24 V devices, power supply units, spare outputs
- Fan function inquiry
- Service functions to switch off 5 V, 12 V and 24 V loads
- Door switch inquiries
- Spare outputs 1 to 3, spare inputs 1 to 4
- SOP button / switch function
- Firmware download
- LCD backlight inquiry, customer panel lighting
- Logo lighting
- Switching a CRT monitor on/off via the power distributor
- 1 Power output for door magnet locking
- PIN pad inquiry with encryption

## Control Panel

The control panel is fixed at the housing behind the printer.

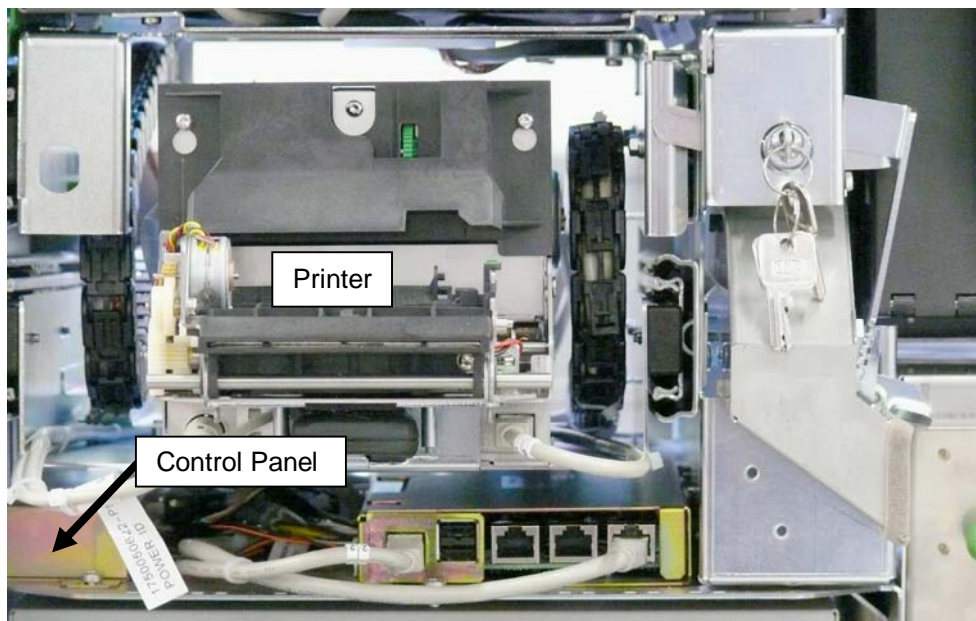

# Power Supply Unit

Open the bottom door and the safe. Pull out the media cash dispenser completely.

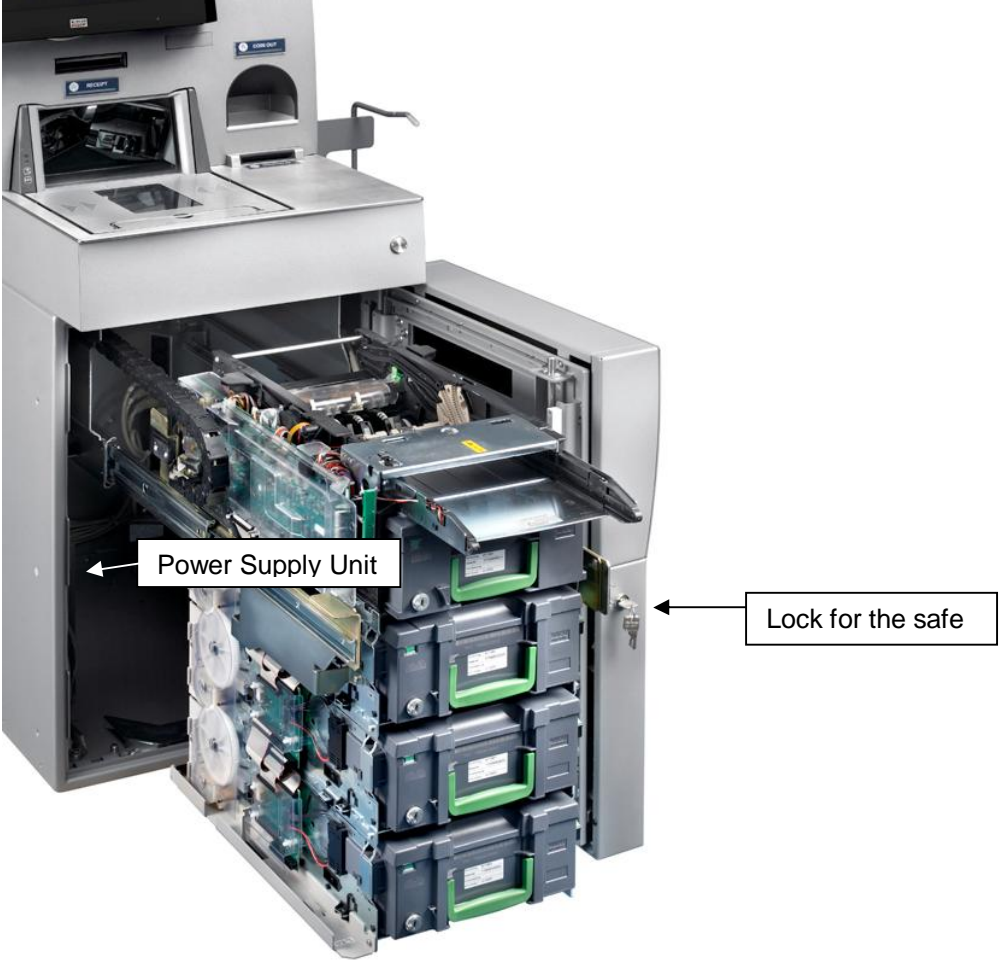

The power supply unit is located in the back of the safe.



**Views**

**Front view**



## Rear view



## Description

The power supply unit supplies all components that do not have their own power supply with the required DC voltages.

The power supply unit is designed for the voltage range 115 / 240 V and is automatically set to the line voltage supplied. However, the limiting values for detection of undervoltage at power input must be set to the input voltage of 115 V or 230 V. It must be set with a slide switch.

The power supply unit has no main switch and changes automatically to standby mode when line voltage is applied.

All outputs are protected against short-circuits and overtemperature. The power supply unit also has a temperature-based switch-off function if overheating does occur.

The unit is cooled by an integrated fan.

## Safety functions

### Short-circuit

If a short-circuit occurs at the outputs, the power supply unit switches off immediately. It switches on again automatically.

**Overvoltage and overtemperature**

In case of overvoltage or overtemperature, the power supply unit switches off immediately and can only be switched on again by switching the supply voltage off and on again (configuration-dependent: e.g. disconnect power plug, press switch on power distributor).

- \*2) Connectors A and C:  
The maximum continuous current at contact 2 (+ 25 V) is 6 A in each case.  
The current limit is 8 A.

Connectors B1, B2, B3:  
The max. total constant load at connector B1, B2 and B3 is 10 A.  
A current of 15 A is permitted for a duration of 10 s every 60 s.  
A peak current of 23 A can be supplied for 300 ms with the same cycle (60 s).



The total load on the 25 V output must not exceed 10 A.

# Proximity Sensor

## Introduction

The proximity sensor is predominantly applied in self-service terminals such as e. g. kiosk terminals or ticket automats. Persons and objects of comparable size who approach the automat are detected by the sensor and are signalled to the application program via evaluation electronics.

The application can react to this message e. g. by sending out acoustic signals or by changing the content on the monitor, as soon as a customer approaches the automat.

Open the front door and swing it up. The proximity sensor is fixed with two screws at the bottom of the printer.

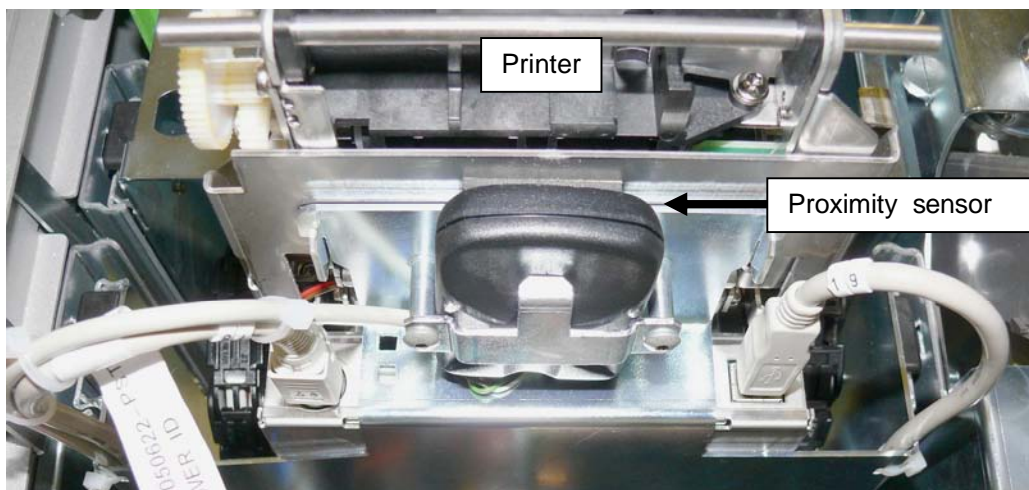

## Function

On radar sensor basis persons as well as objects of comparable size, who move within the detection area of the sensor, are detected. The signal of the sensor is extended by means of auxiliary electronics; i. e. the signal backspaces 15 seconds after the last detected movement.

In case of detection of a further movement within this time frame the delay time will be restarted.

- i** The sensor does only react on movement. A person standing in front of the automat without moving will not be detected. It is thus not possible to tell by means of the output signal of the sensor, if a person is present in front of the automat or not.

Starting from the sensor surface the sensitivity area is ball-shaped.

## Waiter Lock

Each transaction is correctly assigned to the personell by using the magnetic key. The magnetic keys are available in 10 different colors.

The magnet keys are waterproof, shatterproof and by the 16-digit key number also safe for clear identification. The operation of the system is very simple, the key is placed onto the magnetic probe (see figure).

The key is held magnetically to the probe and transmits the data by an electrical RS232 interface. The readout of the data may be integrated easily in a software application.



## Scanner (Scale optional)

### Scanner Maintenance

Keep scanner windows clean. This will improve productivity and reduce rescans. Replace scanner glass when excessive scratches are evident.

### Scanner Usage

Minimize handling of heavy/bulky products. Leave these items in the cart and use an alternative entry method such as key entry of short PLUs, or handheld scanning.

Regularly train cashiers in proper scanning methods and ergonomics principles, such as: Develop a smooth fluid motion during scanning, sharing work equally between hands. Use the entire hand for grasping and lifting items. Since the scanner reads labels on all four sides plus the top and bottom, there is no need to turn a bar code towards either of the scanner windows.

Develop efficient scanning motions, not necessarily faster hand movements. Simply slide the item across the scanner's horizontal window with as little orientation motion as necessary. Leave items in an upright position; do not lift and tilt. Do not favor either the vertical or horizontal window; slide items across the scanner in their natural orientations on the checkstand as much as possible.

### Scanning Items

To scan items, slide or push them through the scan zone. The scanner will work equally well with either a left-to-right or right-to-left motion through the scan zone. There is no need to reorient an item's bar code since the scanner can "see" the left, right, front and back side, as well as the top and bottom of an item.

### Proper Scanning Technique

The scanner was designed to provide the ultimate in ergonomic enhancements for Point-Of-Sale (POS) scanning. To take advantage of these advancements.

Practice the techniques below to improve scanning efficiency:

- Move the product across the horizontal window.
- Since the scanner reads labels on all four sides plus the top and bottom, don't favor either the horizontal or vertical scan windows.
- Keep items in their natural orientation.
- Remember to slide or push items rather than picking them up. By avoiding any gripping, twisting and rotation of your hands and wrists, you can prevent repetitive motion injuries. This technique also relieves you from lifting possibly thousands of pounds per day.
- Develop a smooth fluid motion during scanning, sharing work equally between hands.
- Use the entire hand for grasping and lifting items.
- Develop efficient scanning motions, not necessarily faster hand movements.
- Learn typical locations for bar codes on packages; avoid "flipping" or rotating the items during scanning.

## Security Scale

Find the security scale under the cover shown in the picture (1). You can easily lift the cover up to calibrate the scale.



### Adjusting the Security Scale Module

To guarantee a faultless working of the security scale the security scale module has to be adjusted by a circular level. To avoid a seating of the scale plating on the housing of the BEETLE POS Tower 100 Scan&Bag, the feet have to be unscrewed for about 6 cm and (have to be) secured.

## Coupon Box

### Emptying the Coupon Box

Open the front door as described on page 3.

Lift the cover of the the coupon box at the back side slightly up (1) and push the cover to the back side (2).



## UPS (Unbreakable Power Supply - optional)

Find the UPS in the housing underneath the security scale. Unlock the door and open it to switch the UPS on/off.



## Appendix

### Changing the Safe Code (LG 39E)

Switch off the device. Insert the key into the lock, turn it to the right and open the bottom door of the BEETLE POS Tower 100 Scan&Bag.

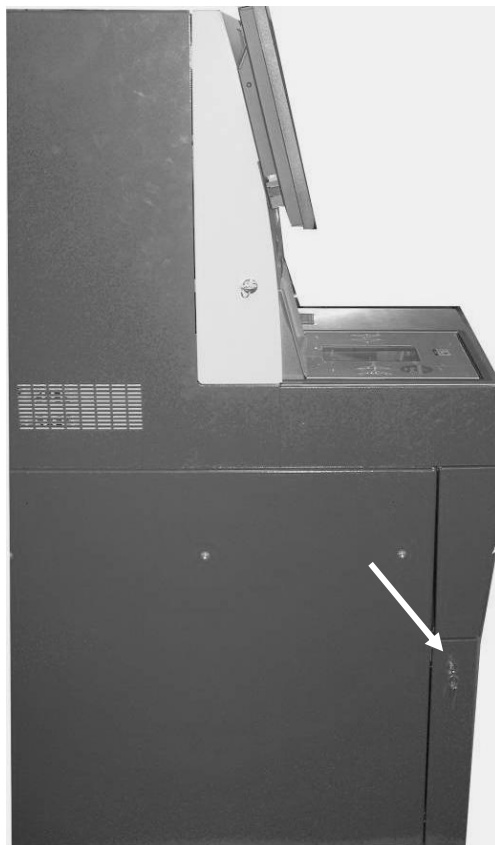

Now enter the code number of the safe in the data field (1), turn the knob (2) to the right and open the door.

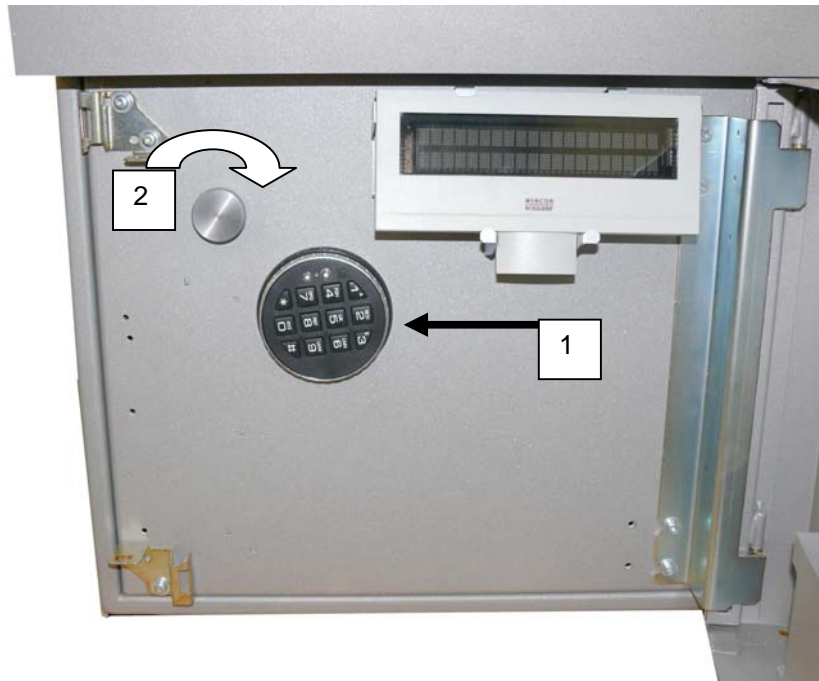

**Lock 39E**

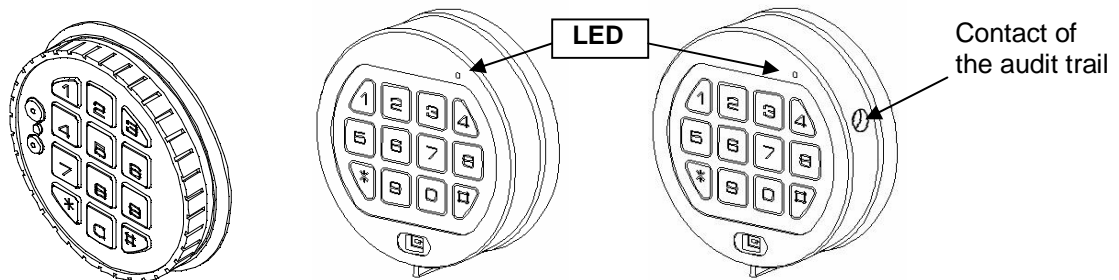

**Generally**

Each pressing of a key is confirmed by a signal (an acoustic signal and a LED flash). A correct code entering is followed by double signal, the wrong code is followed by triple signal. Pauses longer than 10 sec will cause deleting of all previous entering and you have to start again.

**Code entering:** Enter the seven-unit numeric code – or a word with 7 characters

a) Operation with parallel code: a double signal is followed.

(manager mode)

**Manager code: 1234567**

**b) Operation with two codes:**

Six unit numeric codes or words with six characters.

(must be programmed)

For opening two valid codes must be entered. The code sequencing is arbitrary, two of all valid codes can open.  
**Manager code: 123456 and 654321**

**Opening:**

After entering of a correct code (double signal) the lock is ready to open for a time of 3 sec.

Turn the keypad by 90° TO THE RIGHT (clockwise) until it stops. **Swingbolt entry is fixed, turn handle boltwork**

When during the ready time for opening (3 sec) no opening is made then the lock will be automatically secured.

**Locking:**

Turn the keypad back so that it is horizontal. **Swingbolt entry is fixed, turn handle boltwork**

**Check the lock to be locked.**

**Wrong try penalty:**

After 4 successive wrong code enters the lock will be cut off for 5 minutes then it will be cut off already after 2 wrong tries. During this wrong try penalty the LED is flashing each 10 sec.

The key pressing is refused with a triple signal.

**Change of code:**

The user can change its code by himself anytime.

**(at the opened door)**

a) Enter the code and keep pressed the last number until the double signal (LED is on) is repeated, press the "0" and enter the new code (double signal), enter the new code once more for its confirmation (double signal).

b) Press "0" for seven times, (when operating with two codes six times "0") enter the old code and then two times the new code (always followed by double signal).

The new code is now active.

In case of wrong entries or pauses during entering the code longer than 10 sec remains valid the old code. When the new code would not be accepted (triple signal) then it is too similar to the code already stored.

**Always enter the new code with the door opened.**

**Silent alarm:**  
(must be programmed)

In case of blackmailing the silent alarm can be started so that you enter the last **code number +1** (e.g. the last number is 9 and the alarm is started with the number 0 instead of 9). The lock function is the same as entering the code for opening.

**Time delay for opening:**  
(must be programmed)

After valid code entering the time delay starts to run, which can be recognized by the LED signal each 2 sec. After delay period expired the time period for opening starts, which can be recognized by alternate acoustic and LED signal each second. During the time period for opening the valid code must be entered to reach the opening.

At the operation with two codes must two valid codes be entered during the time period for opening to succeed.

When no valid code is entered during time period for opening the lock is time secured again.

When the delay should be interrupted press the key "0".

Time delay override:  
(must be programmed)

The user ID# 9 ( WTU ) can open immediately. At the operation with two codes the ID# 9 is entered as the second code.

**Power supply:**

When the capacity of the battery is too low a series of acoustic signals is heard at opening. (According to the capacity of the battery it may be also only 3, 4 or 5 acoustic signals!) Change the battery!

Use 9V ALKALINE batteries only!

The codes are stored in the lock even without power supply.

The battery compartment is installed down in the keypad.

When connected to the alarm equipment through the interlock device "SP" then the power supply is secured from this place.

**Safety notice:**

Change the code immediately and carefully store on a secure place, do not use your personal data (telephone number, date of birth etc.) as a code.

**LED and acoustic signals:**

1 x short signal	enter confirmation
2 x short signal	valid code entered
3 x short signal	wrong code, not accepted
6 x short signal	remote interlock, the alarm equipment was not released

LED signal each 10 sec. 1 flashing	Interlocking time after a wrong entry
------------------------------------	---------------------------------------

LED signal each 2 sec. Time	Delay for opening is running
-----------------------------	------------------------------

Alternate LED and acoustic signals	Time period for opening is running
------------------------------------	------------------------------------

A series of acoustic signals, ca. 3 sec. Low battery capacity

Still available ca. 10 openings.

Dependent of the battery capacity there may be also less acoustic signals. Therefore, the battery change should be made also in case of double or triple signals without ready time for opening.

**Use ALKALINE batteries only!**

**Programming Manager**

<p><b>Manager function Overview</b></p>	<table border="0"> <tr> <td>a)</td> <td>Manager code change (ID Nr. 0)</td> <td>function "0"</td> </tr> <tr> <td>b)</td> <td>Enable user (ID Nr. 1-9)</td> <td>function "1"</td> </tr> <tr> <td>c)</td> <td>Disable user</td> <td>function "2"</td> </tr> <tr> <td>d)</td> <td>Remove user</td> <td>function "3"</td> </tr> <tr> <td>e)</td> <td>User status inquiry</td> <td>function "7", keep pressed</td> </tr> <tr> <td>f)</td> <td>Reading the audit trail</td> <td>function "7"</td> </tr> <tr> <td>g)</td> <td>Setting the time delay for opening</td> <td>function "9"</td> </tr> </table>	a)	Manager code change (ID Nr. 0)	function "0"	b)	Enable user (ID Nr. 1-9)	function "1"	c)	Disable user	function "2"	d)	Remove user	function "3"	e)	User status inquiry	function "7", keep pressed	f)	Reading the audit trail	function "7"	g)	Setting the time delay for opening	function "9"
a)	Manager code change (ID Nr. 0)	function "0"																				
b)	Enable user (ID Nr. 1-9)	function "1"																				
c)	Disable user	function "2"																				
d)	Remove user	function "3"																				
e)	User status inquiry	function "7", keep pressed																				
f)	Reading the audit trail	function "7"																				
g)	Setting the time delay for opening	function "9"																				
<p><b>Manager code*</b></p>	<p>It is possible to open the lock with the factory code 1 2 3 4 5 6 7.  Change the code immediately.</p>																					
<p><b>A) Manager code change (at the opened door)</b> <i>(function 0)</i></p>	<p><b>Enter the manager code</b> (or the old code) <b>and keep pressed the last number</b> until the double signal (LED is on) is repeated, <b>press the "0"</b> and enter the new code (double signal), enter the new code once more for confirmation (double signal). The new code is now active. In case of wrong entries or pauses during entering the code longer than 10 sec remains valid the old code remains valid.</p> <p>When the new code is not accepted (triple signal), it is too similar to the code already stored. Enter a new code.</p>																					
<p><b>B) Enable user*</b> <i>(function 1)</i></p>	<p><b>Enter the manager code and keep pressed the last number</b> until the double signal (LED is on) is repeated, <b>press the "1"</b> (double signal), <b>enter the user ID No (1-9)</b> e.g. "2" (double signal), enter the user code (double signal), enter the user code once more for confirmation (double signal).</p> <p>When a triple signal is followed then the code confirmation was wrong or the code is too similar to the already stored code. Enter a new code.</p>																					

<b>C) Disable user*</b> <i>(function 2)</i>	<p>Enter the manager code and <b>keep pressed the last number</b> until the double signal (LED is on) is repeated, <b>press the "2"</b> (double signal) <b>and enter the user ID Nr. e.g. "2"</b> (single signal). The user (ID Nr. 2) is now disabled for such time period until again enabled with the function „1“ and the ID Nr. "2".</p>
<b>D) Remove user*</b> <i>(function 3)</i>	<p>Enter the manager code and <b>keep pressed the last number</b> until the double signal (LED is on) is repeated, <b>press the "3"</b> (double signal) <b>and enter the ID Nr. e.g. "2"</b> (single signal). The user (ID No 2) is removed.</p>
<b>E) User status inquiry</b> <i>(function 7)</i>	<p>The Manager can anytime make the inquiry, which user is enabled, disabled or removed. <b>Enter the manager code and keep pressed the last number</b> until the double signal (LED is on) is repeated, <b>keep pressed the "7"</b> until the double signal is once more repeated. <b>Press the user ID No (1-9) and watch the signal:</b></p> <p>1 acoustic signal = enabled</p> <p>2 acoustic signals = disabled</p> <p>3 acoustic signals = removed</p> <p>Long acoustic signal = disabled, it can not be enabled</p> <p>Finish: press "0".</p>

(\*) At the **operation with two codes** (4 eyes principle) the valid user code must be entered before the manager code to be able to do the programming. Six-unit code, manager 123456.

<p><b>F) Reading the audit trail</b></p>	<p>In the lock memory records of the last 50 openings are stored with the user ID, which can be read on a PC or laptop.</p>
<p><i>PC setup</i></p>	<p>In a PC with Windows 95 (or later) the program "LG-View 3x" ("SetupExe") is loaded and the COM port is set with the parameters „1200 bauds, non parity, 8 data bits, 1 stop bit“. When the laptop has no COM port then this connection must be made with the PCMCIA card (RS 232) or a corresponding USB adapter. Start the program "LG-View 3x" and set the corresponding port in the item KONFIGURATION (configuration). Connect the interface/data reading cable PN 42160 to the corresponding port.</p>
<p>Start program</p>	<p>Start the program „LG-View 3x“ and click with the mouse on the safe symbol (start acquisition). Insert the interface connector from the side into the keypad 3750K. For the keypad 3750 on the lock an adapter cable is used.</p>
<p><i>Reading the audit trail (function 7)</i></p>	<p>The item „Infos“ offers you a message about the lock status. The user status is shown in a ten-unit group of characters with "manager" first and second to tenth place the user numbers 1 - 9.</p> <p>Meaning: I = initialized, code is active.</p> <p>E = (enrolled) code changed (manager only)</p> <p>D = (disabled) code disabled.</p> <p>- = removed, the code can be entered again.</p> <p>B = blocked, code cannot be enabled.</p>

<p><b>G) Time delay for opening*</b> <i>(function 9)</i></p> <p>Time delay override</p>	<p>Manager can set the time delay for opening with the function „9“.</p> <p>The values of the time delay 1-99 minutes and of the time period for opening 1-19 minutes are entered in a four-unit block where the first two places are minutes of the delay and the further two places are minutes of the time period of opening (min. 1 minute).</p> <p>If the setting should be made with 10 minutes of time delay and 5 minutes of time period for opening then the four-unit block is as follows: „1005“</p> <p><b>Enter the manager code and <u>keep pressed the last number</u> until the double signal (LED is on) is repeated. Press „9“ and enter the time block „1005“ (double acoustic signal) and confirm with a repeated entering of „1005“ (double acoustic signal).</b></p> <p><b><u>The changing of the time values can be made only in the time period for opening.</u></b></p> <p>If the “time delay override” is set then the user ID Nr. 9 can open immediately (e.g. WTU). When <u>operating with two codes</u> then the code of the ID No 9 is entered as <u>second</u> one. This "override" code of the ID No 9 can be enabled only in the time period for opening or before the time delay is set.</p>
<p><b>Lock programming</b></p>	<p>The program selection of the lock (two codes, alarm, delay override) is made by programming on PC (39E Setup) or manually on the keypad.</p>

(\*) At the **operation with two codes** (4 eyes principle) the valid user code must be entered before the manager code to be able to make the programming. Six-unit code, manager 123456.

**Programming on PC**

<p><b>FACTORY-Mode</b> (Pre-Setup-mode)</p>	<p>The lock may be installed in the factory mode. It is opened when pressing the key “1” and it sends at the same time the alarm. Thus the simple and flexible storing is reached and the simple operation during manufacturing is secured.</p>
<p><b>Programming on PC</b> PC setup</p> <p><b>Code length</b></p> <p><b>User</b></p> <p><b>Program transfer:</b></p>	<p>On PC (laptop) the operating system Windows must be installed and the program LG-39E-SETUP (requiring 4MB) must be loaded. Insert the interface cable into the corresponding COM port of your PC. When the laptop has no COM port this connection must be made with the PCMCIA card (RS 232) or a corresponding USB adapter. Configure the port (1200 bauds, non parity,8 data bits, 1 stop bit) and start the program LG39E-SETUP. The programming is made in clear text (english) and is very simple.</p> <p>When <b>operating with a parallel code</b> (each code is opening) the code length must be of seven-units.</p> <p>When <b>operating with two codes:</b> The code length is six-units.</p> <p>Activate user:</p> <p>The preset codes can be overwritten. The active users to whom no code was assigned can be enabled later.</p> <p>Not activated users cannot be enabled later.</p> <p>Insert the <b>interface connector</b> into the keypad (or into the adapter) of the lock, which is ready for operation, and click the mouse on the item “TRANSMIT /Send“ and then press the key “0” on the lock keypad.</p> <p>With this program it is possible to make the programming of several locks. It is possible to save it for later consumer programming (File/ Save as:..).</p>
<p><b>Exit the Factory-Mode</b></p>	<p>After SETUP programming the lock is still in Factory mode and can be opened with the key “1”. The programming will be effective when the factory mode is finished: keep pressed “0” until the double signal is repeated and enter the manager code. <b>The program must be “frozen” by the change of manager code. The lock is ready for operation.</b></p>

<b><i>Reset to the Factory Mode</i></b>	<p>When the programs shall be changed the reset with the Reset-Box is necessary for a new programming.</p> <p>Disconnect the lock from the power supply for ca. 3 minutes (remove the battery) and insert the Reset-Box into the „BAT“ inlet of the lock.</p> <p>The lock is in the Factory Mode (opening with key “1”).</p> <p>The Reset Box must be connected to a 9V ALKALINE battery.</p>
<b><i>Safety notice</i></b>	<p>Do not assign code to the users of no use for the time being. Manager can do this later.</p>

**Manual programming**

<b>Factory Mode</b> <i>(Pre-Setup-mode)</i>	<p>The lock may be installed in the factory mode. It is opened when pressing the key "1" and it sends an alarm.</p> <p>Thus the simple and flexible storing is reached and the simple operation during installation is secured.</p>
<b>Exit the Factory-Mode</b>	<p>Keep pressed the key "0" until the double signal is repeated. Now the manager code is 555555.</p>
<b>Code length and program selection</b>	<p>The code length and program selection are made with the function "8" and a group of two characters. The first place in this group of characters is the code length the second one is the program number.</p> <p>Program 0 = Manager mode (operation with parallel code)</p> <p>Program 1 = Manager mode with delay override</p> <p>Program 2 = Operation with two codes</p> <p>Program 3 = Two code operation with delay override</p> <p>Program 4 = Manager mode with alarm</p> <p>Program 5 = Manager mode with alarm and with delay override</p> <p>Program 6 = Two code operation with alarm</p> <p>Program 7 = Two code operation, alarm and delay override</p>
<b>Programming</b> <i>(function 8)</i>	<p>Enter the manager code "555555" and <u>keep pressed</u> the last number <b>until the double signal (LED is on) is repeated and enter "8". Then enter the group of two characters made of code length and program number (double signal) and repeat the enter of the group for confirmation (double signal).</b></p> <p>In case of the seven-unit codes the manager code is 7 x "5".</p>

<p><b>Enable user</b> (function 1)</p>	<p>Enter the manager code and keep pressed the last number <b>until the double signal (LED is on) is repeated then press "1" and the user ID No (1-9) and enter the code two times.</b></p> <p>The disabled users cannot be enabled after the change of the manager code.</p>
<p><b>Program "freeze"</b></p>	<p>With the change of the manager code the program is „frozen“ and it can be changed only with resetting and with a new programming.</p>
<p><b>Reset to the Factory Mode</b></p>	<p>Disconnect the lock from the power supply for ca. 3 minutes (remove the battery) and insert the Reset-Box into the „BAT“ inlet of the lock.</p> <p>The Reset Box must be connected to a 9V ALKALINE battery.</p> <p>The lock is in the Factory mode again (Pre-Setup-Mode).</p>
<p><b>Safety notice:</b> Do not assign codes to the users of no use for the time being.</p> <p>Remove the codes. (Function 3 and user number)</p>	



## Environmental Requirements

<b>Operating temperature</b>	
<b>Ambient temperature:</b>	5° C – 35° C
<b>Humidity:</b>	5% r.h. (1 g/m <sup>3</sup> ) – 85% r.h. (25 g/m <sup>3</sup> )
<b>Temperature change:</b>	0.5 K/min (max. 7.5K/30 min)
<b>Barometric pressure:</b>	70 kPa – 106 kPa (70kPa corresponds to an installation at approximately 3000 meters above sea level) Installation environments with long periods of sunshine should be avoided
<b>Storage conditions</b>	
<b>Ambient temperature:</b>	5° C – 40° C
<b>Humidity:</b>	5% r.h. (1 g/m <sup>3</sup> ) – 85% r.h. (25 g/m <sup>3</sup> ) 0.5 K/min
<b>Temperature change:</b>	0.5 K/min (max. 7.5K/30 min)
<b>Transport conditions</b>	
<b>Ambient temperature:</b>	-25 °C – 60° C
<b>Humidity:</b>	15% r.h. (1 g/m <sup>3</sup> ) – 98% r.h. (32 g/m <sup>3</sup> )
<b>Temperature change:</b>	-25° C / 25° C

## Cleaning Instructions

- Always **turn off the system** before cleaning.
- The glass surface of your Touch Screen should be cleaned with a mild, abrasive free, commercially available glass cleaning product.
- All pH neutral materials (pH 6 to 8) are good for cleaning. Cleaners with pH values 9 to 10 are not recommended. Cleaning with water and isopropyl alcohol is possible as well.
- Do **not use** solvents containing acetic acid.
- Use a soft, fine-meshed cloth to clean the surface. Dampen the cloth slightly and then clean the screen.

A wrong maintenance may cause damages to the screen, which are not covered by guarantee or warranty.

## Maintenance and Service

When carrying out work on the components and modules that carry an electrical charge, this equipment must first be disconnected from the power supply. Besides switching off the power switch on the power distributor, the safety plug must be disconnected from the power distributor.

### Device housing

Clean the housing with a vacuum cleaner or cloth. Eliminate damage to paint if necessary and possible.

### Maintenance for rotating top module

Clean the rotating surface for the top module after 500 rotations or at least once a year. Clean it with commercially available cleaner.



Dry rotating surface after cleaning!

### Approved Cleaning Materials

The items listed below can be ordered from Wincor Nixdorf branch office or your Wincor Nixdorf sales partner.

Product Name	Order Number	Explanations
Professionell cleaning set for EDP devices  100ml plastic cleaner in a pump bottle  50 dust cloths  10 keyboard swabs for places difficult to reach	01750097335	For cleaning and maintaining keyboards and varnished and plastic-coated housing
Damp cleaning cloths  Dispenser box with 100 cloths	01750097332	For cleaning and maintaining delicate EDP devices, keyboards and housing
Dry cleaning cloths  Antistatic and fluff free  (Pack with 300 cloths)	01750097334	For cleaning display panes
Compressed air spray  PRESSAIR  400ml bottle without a valve,  70cm hose	01750097331	Cleaned compressed air, FCKW-free, for removing loose dust and dirt particles
Cloth with ISOPROPYL 1000 pieces	01750104065	Pure isopropyl alcohol for cleaning display
Cleaning card	01750016388	Form cleaning magnetic heads and chip contacts in ID card readers

Please note the manufacturer's specifications on the packaging and on the information sheet included in the packaging. The product may be damaged or soiled if materials are used that are not approved or if they are used improperly.

## Important Notes

Appliances supplied by Wincor Nixdorf International GmbH comply with the respective safety regulations for data-processing installations and information technology installations, including electrical office equipment for use within an office environment.



To disconnect the POS Tower 100 Scan&Bag from the mains, disconnect the CEE connection or disconnect it by the fuse of the building installation.



If UPS is installed, you must switch off this too, to separate POS Tower 100 Scan&Bag from power completely.

- Appliances may only be repaired by authorized technicians.
- Unauthorized opening of the housing or inexperienced repairs can result not only in considerable personal danger, but will also invalidate your warranty and liability protection.
- Always consult the enclosed documentation before doing any work with this appliance.
- If this device is brought from a cold environment into a heated place of business, condensation may occur. Before operation, the device must be completely dry. Therefore, an acclimatization period of at least two hours must be adhered to.
- Always lay the supply leads and cables in such a way that they cannot be stepped on or tripped over.
- Exchange damaged cables immediately.
- In order to completely disconnect the device from the power source, turn the device off and use the separator in the fuse box\building installation.
- Make sure that no objects (such as paper clips) can reach the interior of the device, since electrical shocks or short-circuits could result.
- To avoid overheating of the power supply unit. Ensure that the POS Tower 100 Scan&Bag receives adequate ventilation.
- During an electrical storm, data cables should not be plugged in or unplugged.
- Keep the device away from vibrations, dust, humidity, and heat.
- Ensure that used parts are disposed of in *an environmentally friendly manner*.
- In case of an accident (such as a damaged housing, entry of liquids or foreign objects), switch the device off and use the separator to completely remove the device from power..
- The POS Tower 100 Scan&Bag is the result of state-of-the-art technology. Therefore, please also ensure that the POS Tower 100 Scan&Bag is operated under modern building and technical conditions in order to ensure flawless and efficient operation. The appliance and other information technology hardware should only be connected to electrical supply networks with a separate protective earth wire (PE). This type of electrical supply network is referred to as a TN-S network. Do not use PEN conductors. Also follow the recommendations set forth in DIN VDE 0100 Part 540, Appendix C2 as well as EN50174-2, §5.4.3. This will help prevent malfunctions.
- When working on the cutter of the printer, the device must be turned off.
- Always keep the ventilation slots free of obstruction to ensure adequate air circulation and avoid overheating.

- Transport the appliance only in its original packaging (to protect against knocks and bumps).
- If a lithium battery is supplied with the appliance, ensure that the battery is replaced with an equivalent type. Otherwise there is danger of explosion! Lithium batteries may only be replaced with identical types or other types recommended by the manufacturer.
- Batteries must be disposed of according to local regulations on the disposal of special waste.

- **Connecting Peripherals**

Use only shielded cables when connecting devices to the system to ensure compliance with international Rules and Regulations for radiated emission as well as to achieve a high immunity against external disturbances.

- **Coin Module**

The CoinXpress (CX) Coin Dispenser is a safe product. All the necessary precautions have been taken to ensure that normal operations and maintenance procedures are safe.



Care should be taken to keep fingers clear of the hinged chassis panels when dumping coins or rotating the hoppers to gain access to the inside of the unit. This area is a potential pinch hazard and may cause significant injury when using hoppers filled with coin.

Wincor Nixdorf International will not be held liable for damages and/or personal injuries brought on by incorrect operation and maintenance practices.

Only a qualified service technician should replace an individual hopper assembly or remove the pcb protective shield to access internal components. Ignoring this warning may void the products warranty.

### **Safety Icons**



Critical Shock Hazards - indicates potentially lethal voltages are present.



Stop! - Identifies important information requiring special attention.



Caution! - Identifies actions requiring caution.



Pinch Hazard - identifies possible pinch hazards

### **Heavy Objects**



Caution: The CoinXpress (CX) Coin Dispenser weighs approximately 21 pounds unfilled with coin. When transporting the unit, avoid bumping or dropping it, which could damage the unit. The coin dispenser should be empty of coin before transporting. If dropped on a body part, the coin dispenser could cause serious personal injury.



Caution: The CoinXpress (CX) Coin Dispenser weighs approximately 65 pounds filled with coin. Do not move filled. Mounting supports should be properly designed to handle the load.



Caution: The CoinXpress (CX) Coin Dispenser should be secured to a sturdy, flat surface before utilizing its hinged chassis to dump and empty a hopper of coin.

- **Cleaning Instructions**

Always turn off the system before cleaning.

specials:

If liquids were spilled over your System switch off the system and disconnect the power plug. Dry the device with a cloth and leave it switched off for a while.

- **LCD-Displays**

If the display element is damaged and the liquid crystal solution leaks out onto your hands or clothing, please wash your hands or clothing immediately under running water for at least 15 minutes, using soap or alcohol. If the liquid comes into contact with your eyes, consult a medical doctor immediately.

Inside the display, the high voltage needed for backlighting the LCD display is generated by the inverter! High Voltage!

Before opening the device, make sure, that the device is disconnected from the main power supply. Opening of the device only by authorized personnel!

### **Note on Laser**

The PSC 82xx Scanner/Scale is not intended for long-term viewing of direct laser light. However, the unit is safe if used as intended.

This scanner meets the following laser/LED power requirements.

- Class IIa Laser—Avoid long-term viewing of direct laser light
- Class 1 EN60-825 (European Standard)

## Certifications of the manufacturer



This device complies with the requirements of EEC directive 89/336/EEC with regard to "Electromagnetic Compatibility" and 73/23/EEC, "Low Voltage Directive".

Therefore, you will find the CE mark on the device or on its packaging.

Devices without integrated UPS according class B.

Devices without UPS according class A.

**Important:** Operation of this equipment in a residential area is likely to cause harmful interference in which case the user will be required to correct the interference at his own expense.

### Note on Radio Interference Suppression

All secondary appliances that are connected to an appliance must be equipped with radio interference suppression in accordance with EC directive 89/336/EEC. Products that fulfill this requirement are accompanied by an appropriate manufacturers certificate bear the CE-symbol or the radio protection symbol. Products that do not fulfill these requirements may only be operated with specific permission of the relevant authorities.

### FCC-Class A Declaration

This equipment has been tested and found to comply with the limits for a Class A digital device, pursuant to part 15 of the FCC Rules. These limits are designed to provide reasonable protection against harmful inter-ference when the equipment is operated in a commercial environment. This equipment generates, uses, and can radiate radio frequency energy and, if not installed and used in accordance with the instruction manual, may cause harmful interference to radio communications.

Operation of this equipment in a residential area is likely to cause harmful interference in which case the user will be required to correct the interference at his own expense. Modifications not authorized by the manufacturer may void users authority to operate this device. This class A digital apparatus complies with Canadian ICES-003.

*Cet appareil numerique de la classe A est conforme à la norme NMB-003 du Canada.*

## Recycling the BEETLE /iSCAN Scan&Bag

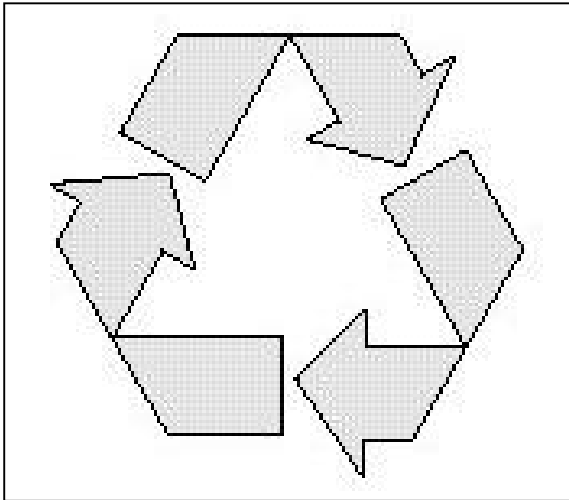

The BEETLE /iSCAN Scan&Bag was designed according to the Wincor Nixdorf standard "Environmentally Conscious Product Design and Development".

The BEETLE /iSCAN Scan&Bag is manufactured without the use of CFCs and CCHs and is manufactured to a great extent out of materials and components which are recyclable.

For recycling purposes do not attach any additional adhesive labels to the device.

Wincor Nixdorf disposes of old devices in an environmentally responsible manner at a recycling center that is ISO 9001 and ISO 14001 certified, as is the entire company.

Follow your local regulations on the disposal of toxic waste (such as the system ribbons).

Your Wincor Nixdorf vendor will answer any questions you have concerning returns, recycling, and disposal of our products.

Wincor Nixdorf International GmbH  
D-33094 Paderborn  
**01750111492A**